

APNH FILTER PRESS



A LEADING TECHNOLOGY APPLICABLE IN A RANGE OF INDUSTRIES

The new family of APNH filter presses comprises heavy-duty, high-capacity equipment developed specifically to dewater metal ores, industrial ores, coal and tailings.

APNH family Filter Presses come with numerous configurations. APNH filter presses can be fitted with plates of:

- › different sizes,
- › materials,
- › configurations (chamber or membrane) and
- › with a range of filter plate pack opening solutions.

Benefits:

- › Longer useful lifetime of the filters thanks to our exclusive pulling system, it reduces strain on structures and frames.
- › Exclusive design based on mechanical simplicity and robustness for easier use, maintenance, and transportation.
- › Smart and fully automatic control system.
- › High output, even in the toughest conditions.
- › High water recovery.
- › Easy replacement of wear parts.

APNH filter presses are designed specifically for use with highly demanding heavy duty processes such as operations to dewater coal, mine tailings, industrial minerals, soil and mineral ore concentrates. Thanks to a combination of efficient drying, draining and squeezing operations, low moisture cakes are achieved.

The APNH filter is sturdy and reliable, thanks to its oversized structure and a design based on simplicity.

- › Higher availability.
- › Low operating costs.
- › Low energy consumption thanks to the fully automatic pulling opening/closing system with the lowest installed power rating on the market.
- › Less space requirement.
- › Simple operation.
- › Increased safety.

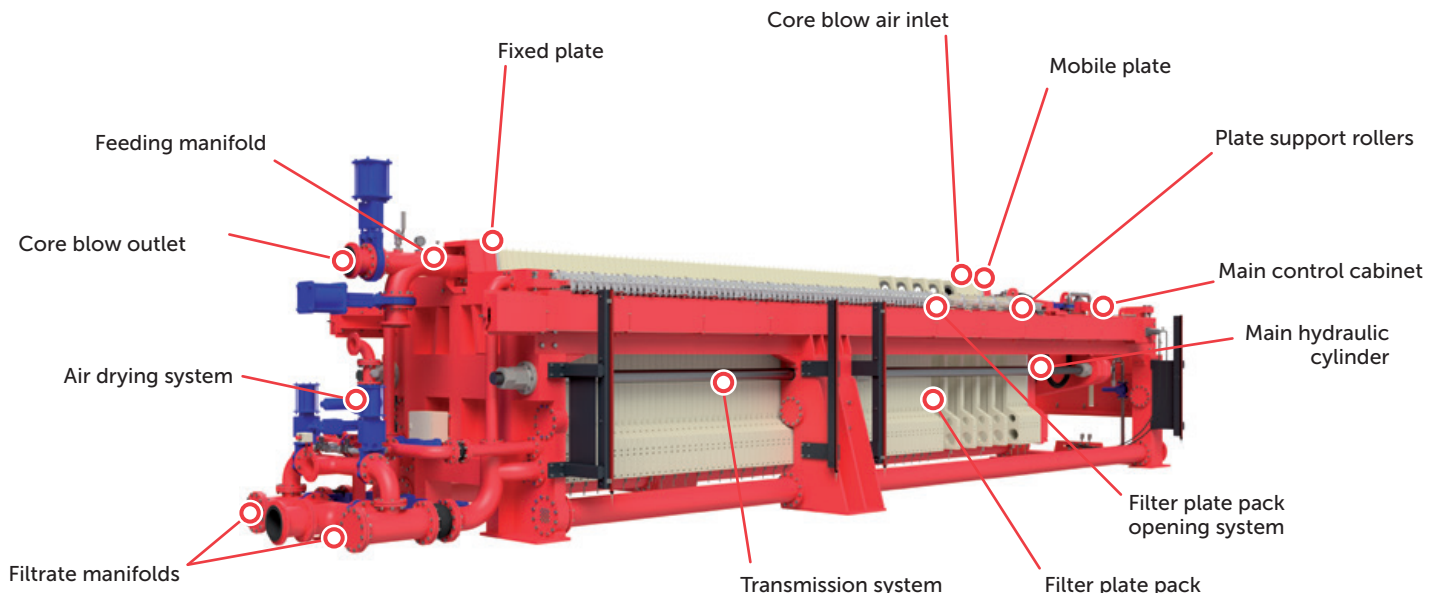

APNH Filter Press

Technical specifications

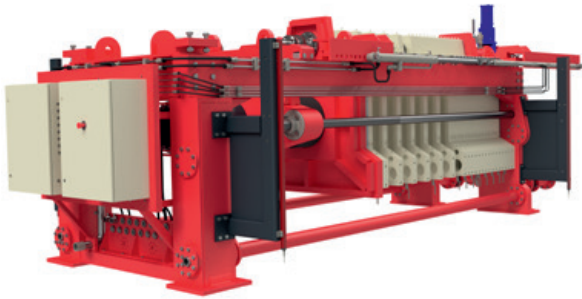

» APNH 12



» APNH 20

MODEL / SIZE	Plates Set C Max. (mm.)	Plates Set C Min. (mm.)	Stroke D (mm.)	Press (bar)	Plates					Plates Feeding			Plates Set Opening			N° Chambers**		Filtering Surface (m²)**		Operations				Finished		Tray		
					PPI	PPE	THH	THI	THE	TF	HF	IF	CO	PA	IN	PP	TH	PP	TH	CD	CW	ICLW	ECLW	CS	SS	DT	IBD	EBD
12 M	1.550	1.336	720	16	✓	✓	*	*	✓	*		✓	✓	19-26	14-20	40-60	25-36	✓	✓	✓	*	✓	✓	✓	✓	✓	✓	✓
12 L	3.810	2.211	720	16	✓	✓	*	*	✓	*		✓	✓	32-55	23-40	70-125	42-72	✓	✓	✓	*	✓	✓	✓	✓	✓	✓	
12 SL	10.910	9.311	720	16	✓	✓	*	*	✓	*		✓	✓					✓	✓	✓	*	✓	✓	✓	✓	✓		
16 S	3.875	1.960	1000	16	✓	✓	*	*	✓	*		✓	✓	18-51	15-41	65-185	45-123	✓	✓	✓	*	✓	✓	✓	✓	✓		
16 M	7.875	3.960	1000	16	✓	✓	*	*	✓	*		✓	✓	52-96	43-77	190-345	129-231	✓	✓	✓	*	✓	✓	✓	✓	✓		
16 L	11.875	7.960	1000	16	✓	✓	*	*	✓	*		✓	✓	97-142	78-113	350-510	234-339	✓	✓	✓	*	✓	✓	✓	✓	✓		
16 ML	15.875	11.960	1000	16	✓	✓			✓			✓	✓	143-187		515-675		✓	✓	✓	*							
16 SL	19.875	15.960	1000	16	✓	✓			✓			✓	✓	188-233		675-840		✓	✓	✓	*							
20 S	2.930	1.685	1400	16	✓	✓	*	*	✓	*		✓	✓	23-40	18-31	150-260	126-217	✓	✓	✓	*	✓	✓	✓	✓	✓		
20 M	6.930	2.250	1400	16	✓	✓	*	*	✓	*		✓	✓	42-89	33-67	275-580	231-469	✓	✓	✓	*	✓	✓	✓	✓	✓		
20 L	10.930	6.250	1400	16	✓	✓	*	*	✓	*		✓	✓	90-137	68-103	585-890	476-721	✓	✓	✓	*	✓	✓	✓	✓	✓		
20 ML	14.930	10.250	1400	16	✓	✓			✓			✓	✓	138-185		900-1200		✓	✓	✓	*							
20 SL	18.930	14.250	1400	16	✓	✓			✓			✓	✓	186-233		1210-1515		✓	✓	✓	*							

PPI: Polypropylene Plate – Internal Collector. **PPE:** Polypropylene Plate – External Collector. **THH:** TH Plate– Evacuation by Hose. **THI:** TH Plate– Internal Collector. **THE:** TH Plate– External Collector. **TF:** Top Feeding. **HF:** Hose Feeding. **IF:** Internal Feeding. **CO:** Complete Opening. **PA:** Plate Set Opening. **IN:** Plate by Plate Opening. **PP:** Polypropylene Plate. **TH:** TH Plate. **CD:** Cake Drying. **CW:** Cake Washing. **ICLW:** Internal Cloth Washing. **ECLW:** External Cloth Washing. **CS:** Coated Steel. **SS:** Stainless Steel. **DT:** Dip Tray. **IBD:** Internal Bomb Bay Door. **EBD:** External Bomb Bay Door. * Set C / Set D: See Page 7 Drawing.

** Variable parameters according to configuration.

* Optional (depending on the requirement of application)

Frame

The heavy duty frame comprises the fixed plate, the end frame and the side bar beams on which the mobile plate, pusher plate (only on APNH16 Filter Press model) and the filter plate pack are supported. The whole assembly is highly robust and has a high load capacity.

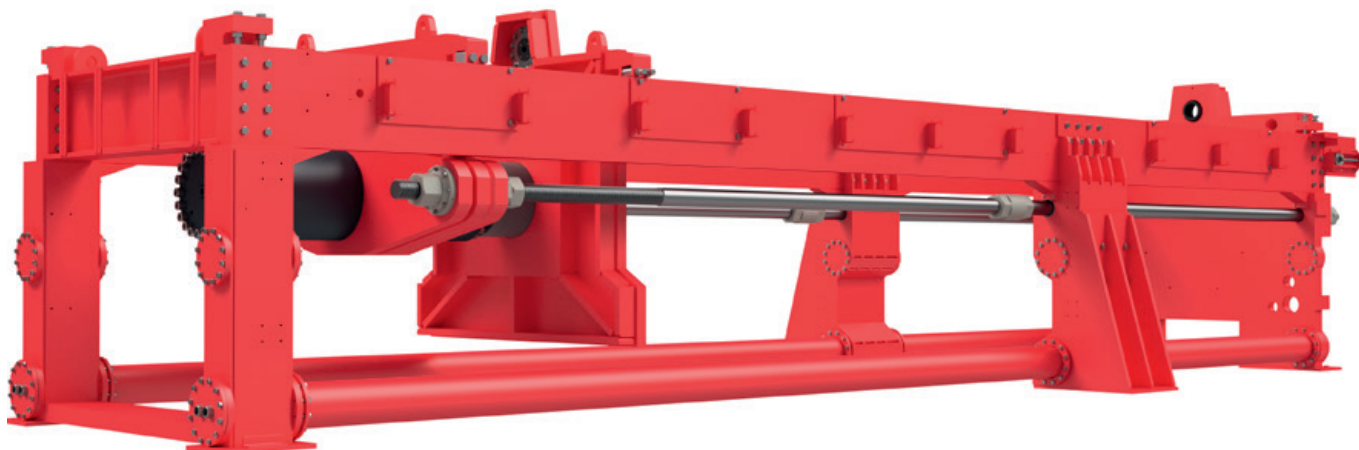
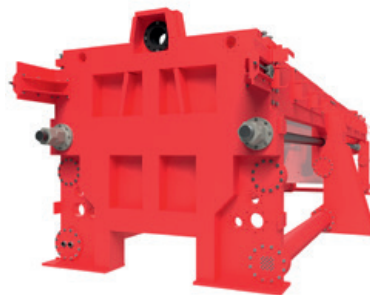

Plate opening and closing system

A hydraulic cylinder is used to open and close the filter press and provide the closing force required during filtration process.

The mobile plate and the pusher plate are supported on the stringers, where the mobile plate is moved in regard to the pusher plate via a single hydraulic cylinder (ISO 3320). The pusher plate is attached to the frame via tie rods.

The advantage of this transmission system means that although the hydraulic cylinder work by compression, the filter package works by traction. This minimises the stresses transferred to the supporting elements of the assembly.



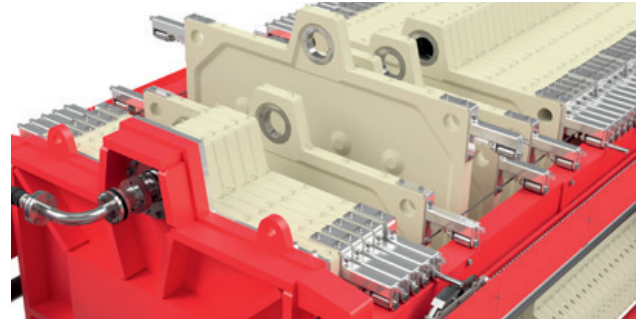
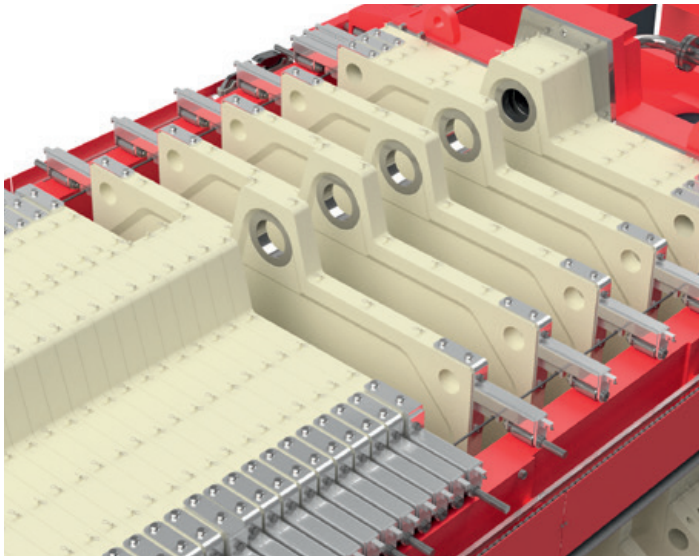

Filter plate pack

APNH filter press are designed to fit different filter plate pack configurations depending on the applications. It is possible to configure the filter press with different plate options like:

- polypropylene plates (PP - Recessed)
- mixed plate packs with polypropylene plates with membrane (PPM - Recessed + membrane)

Both configurations are based on external top feeding system. The filtrate manifolds can be internal (PPI) or external (PPE) depending on the nature of the solids to be filtered.

The plates are hung from the filter press frame on rollers, which enables them to swing during the plate pack opening, thus improving cake discharge.



Filter plate pack opening

The filter plate pack opening system has been designed to ensure fast, effective, and complete automatic filter press cake discharge.

Depending on the size of the filter press, the system may use two synchronous lateral movement slides, auxiliary hydraulic cylinders or pneumatic modules that move together.

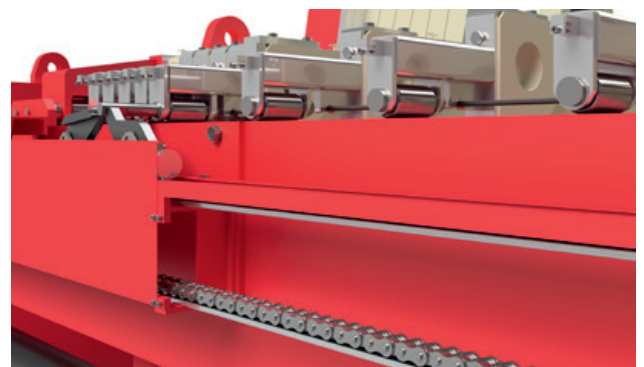
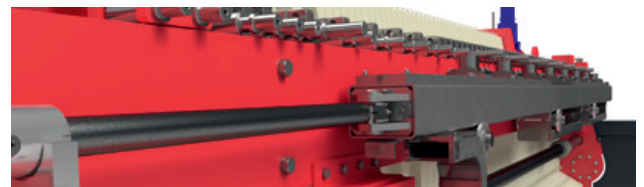

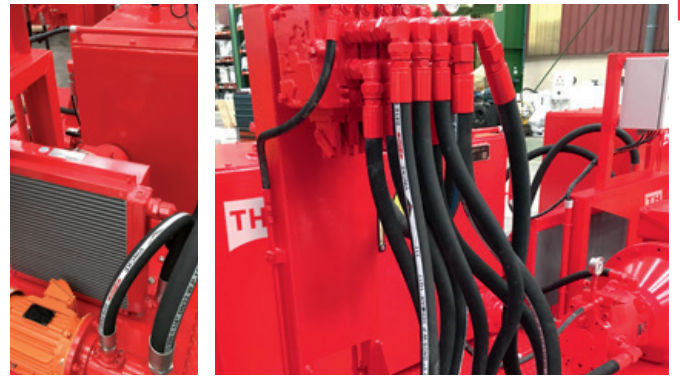
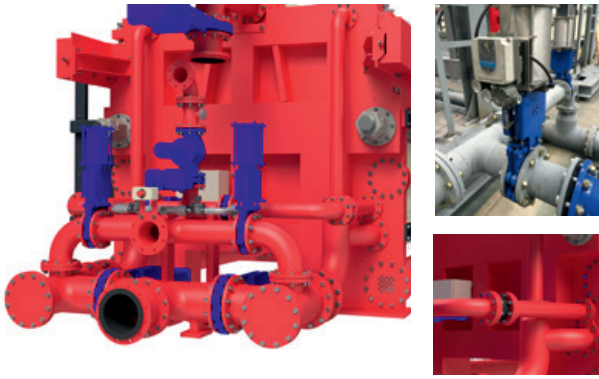

Operational versatility

APNH filter press versatility in terms of plate selection, feeding system choice and different discharge system allows it to be used in numerous operations depending on the requirement of each application and thereby offering tailor made solution for each case:

- > Top Feeding (TF) via a main manifold created on the top of the filter package when it is closed.
- > Slurry is flushed out of the feeding manifold with compressed air after each filter press cycle (Core blow).
- > Removal of filtrate via manifolds designed to optimise the dewatering capacity of the equipment, with hoses interlinking the chambers with the manifolds.
- > Optional cake drying (CD) by replacing residual liquid with compressed air, via inlet system.
- > Optional cake washing (CW) by replacing residual liquid, with washing liquid being run through them.
- > Cloth wash (ICLW) as back wash of the filter cloths by flushing wash water through the filtrate outlet manifolds. This system extends the useful lifetime of the filter cloth by reducing clogging and prevents damage during cleaning.
- > The filtering surfaces of the filter cloths are washed (ECLW) with pressurised water from an external collector fitted with diffuser nozzles to sweep the whole surface area of the cloths. This system enables effective removal of fines from the filtering area and cleans the plate sealing area.

Hydraulic power unit (HPU)



HPU handles the various filter press hydraulic processes (main opening and closing, filter plate pack discharge systems, etc.) via a combination of a high flow-rate pump and a high-pressure pump. This system optimises closing/opening times and pressure required in the hydraulic operations.

The assembly comprises of a frame that houses the oil tank designed for easier cooling, the hydraulic motor pumps, the hydraulic block and distributors, the oil filter, the level and temperature gauges and the electrical connection cabinet.



Smart and fully automatic control system

APNH filter press have two separate connection cabinets located on the rear gantry: one for connecting and powering all the pneumatic parts of the equipment and the other for connecting the electrics.

Filter operation is controlled via software developed by TH, run on a specific PLC which is built into an electrical cabinet along with the HMI screen for monitoring and parameterisation, designed to be located close to the equipment. If necessary, this PLC can be linked to the one in the general plant control room.

The system also includes controls for the hydraulic power unit of the filter press, with an option to upgrade it if necessary, to incorporate other units and equipment used in processes at the plant, both upstream and downstream from dewatering.

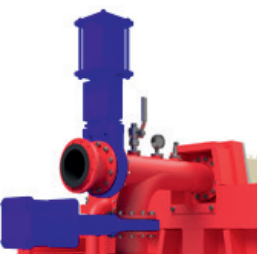

APNH Filter Press

Sizes

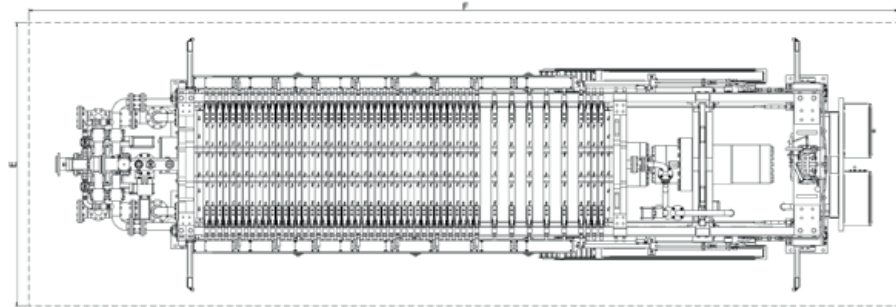
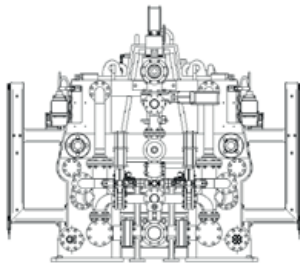
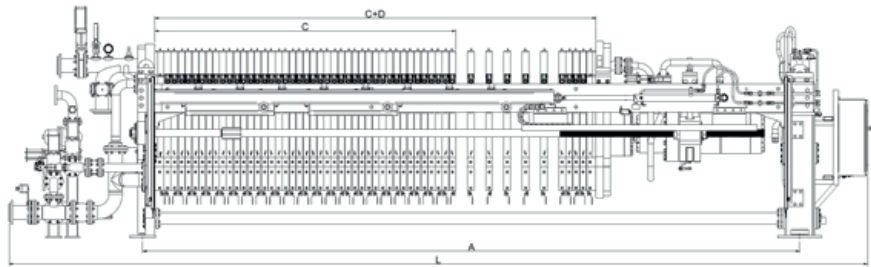
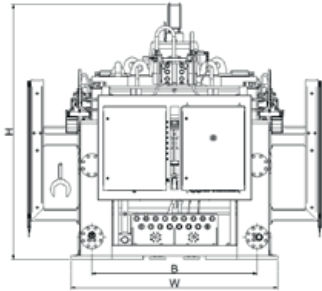

General Dimensions (mm)

MODEL / SIZE	L	H	W	A	B	E	F
12 M	6.760	2.427	2.738	4.610	1.575	4.000	8.500
12 L	9.160	2.427	2.738	6.905	1.575	4.000	11.000
12 SL	16.260	2.427	2.738	14.005	1.575	4.000	18.000
16 S	10.255	2.890	3.085	7.765	1.855	4.500	12.000
16 M	14.255	2.890	3.500	11.765	1.855	5.500	16.000
16 L	18.255	2.890	3.500	15.765	1.855	5.500	20.000
16 ML	22.255	2.890	3.500	19.765	1.855	5.500	24.000
16 SL	26.255	2.890	3.500	23.765	1.855	5.500	28.000
20 S	10.960	3.530	3.805	7.730	2.445	6.000	13.000
20 M	14.960	3.530	4.020	11.730	2.445	6.000	16.000
20 L	18.960	3.530	4.020	15.730	2.445	6.000	21.000
20 ML	22.960	3.530	4.020	19.730	2.445	6.000	25.000
20 SL	26.160	3.530	4.020	23.730	2.445	6.000	29.000

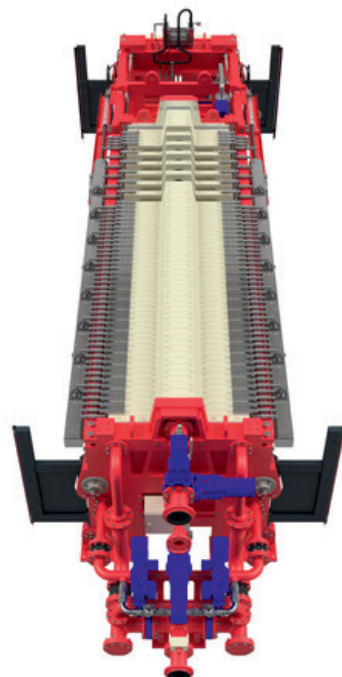



HEADQUARTERS

Aritz Bidea, 65
48100 Mungia, Vizcaya (Spain)
Tel.: +34 946 740 500
info@thsa.com

ECUADOR

GUAYAQUIL

Av. Francisco Orellana, 8º
Callejón 23A-NE
Ciudadela Los Vergeles, Manzana 221
Guayaquil, Guayas (Ecuador)
Tel.: +593 42 658 744
info.ecuador@thsa.com

MEXICO

Calle Puerto Tampico s/n
Parque Industrial Alfredo V. Bonfil
82050 Mazatlán, Sinaloa
Tel.: +52 669 176 85 06
info@thmexico.com

INDIA

Eco Center, Ambuja Neotia, 610, 6th
Floor, EM Block, Salt Lake Sector-V
Kolkata - 700091 (India)
Tel.: +91 33 71658001-71658004
info.india@thsa.com

www.thprocess.com

TH COMPANY

