

ISOLATION GATES QUESTIONNAIRE

Name:	Phone:	Email:
Company:	Site:	Project:

Material details

Material being handled?	Particle size distribution?		
Is the material <input type="checkbox"/> Non abrasive <input type="checkbox"/> Lightly abrasive <input type="checkbox"/> Moderately abrasive <input type="checkbox"/> Highly abrasive			
Bulk density	Moisture content	Temperature	Angle of repose
Wall friction angle	Effective angle of internal friction		

Plant requirements

Describe the isolation application	
Aperture size and shape to be isolated (bin inlet to be larger than aperture)	
Opening direction (along the length or width)	Estimated mass of material above the gate
Is the gate expected to open under flow and first fill conditions (full bin)? <input type="checkbox"/> Yes <input type="checkbox"/> No	
Is the gate expected to seal under +/- gas pressure? <input type="checkbox"/> Yes <input type="checkbox"/> No	
Is the gate required to meter or control the flow? <input type="checkbox"/> Yes <input type="checkbox"/> No	Transmin to include instrumentation? <input type="checkbox"/> Yes <input type="checkbox"/> No

Bin dimensions - refer to drawing for reference

H =	D =
L =	B =
Half hopper angle =	

General

Describe any special requirements?
Describe operating frequency?
Describe the battery limits?
Any special materials or finishes required?
Does the design need to comply with any client specific standards or specifications? <input type="checkbox"/> Yes <input type="checkbox"/> No

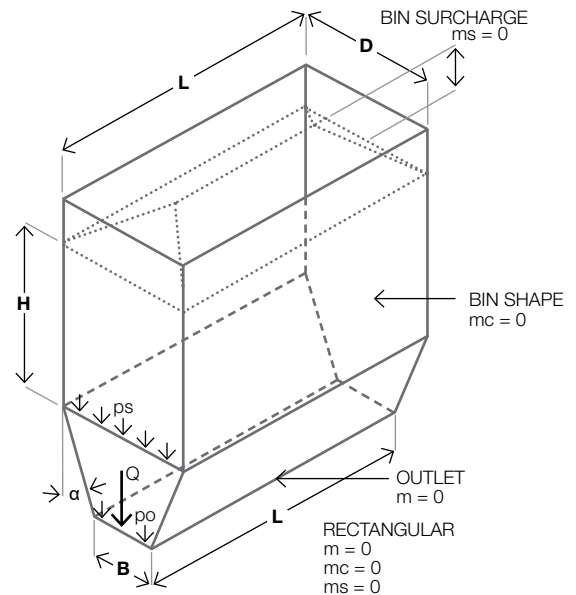

Please attach a sketch of the working area if available.



HEAD OFFICE

Western Australia
Local Call: 1300 127 091
International Call: +61 (0) 8 9270 8555
Email: wasales@transmin.com.au
Address: 33-37 Denninup Way Malaga
 Perth, Western Australia, 6090

Queensland & Northern Territory
Local Call: 1300 800 609
International Call: +61 (0) 8 9270 8555
Email: qldsales@transmin.com.au

INTERNATIONAL OFFICES

North America Email: sales.ca@transmin.com.au
South America Email: sales.sa@transmin.com.au
India Email: sales.in@transmin.in