

COMPLETE SOLUTIONS FOR BULK MATERIALS HANDLING

EQUIPMENT, PARTS & SERVICE, CONTROLS & AUTOMATION



TRANSMIN



1987

THE YEAR TRANSMIN WAS
FOUNDED



60+

COUNTRIES EQUIPMENT
DEPLOYED IN



END-TO-END

FULL LIFE CYCLE SUPPORT
FROM ENGINEERING TO SERVICE



DECADES OF EXPERTISE. PROVEN PERFORMANCE. TAILORED SOLUTIONS.

Transmin is a leading provider of innovative bulk materials handling equipment and systems, delivering cutting-edge solutions to industries across the globe. With decades of experience and a strong focus on engineering excellence, Transmin specialises in engineering, supplying, and servicing equipment for mining, minerals processing, and heavy industries.

Our commitment to safety, reliability, and efficiency has earned us a reputation for delivering high-performance solutions tailored to the specific needs of each client. From concept to completion, Transmin is your trusted partner in materials handling innovation.

CAPITAL EQUIPMENT

Low Profile Feeder™ (LPF)	2
Apron Feeders	4
Belt Feeders	5
BoomerHD Rockbreakers	6
RockLogic	8
Isolation Gates	10
Lime Mixing & Dosing Plants	12
Flocculant Mixing Systems	14
Ball Charging & Grinding	
Media Handling	16
Bulk Storage Silos	17
Special Products & Projects	18

AGENCY LINES & SERVICE

Aftermarket	19
ConveyorPro	20
Martin Engineering	22
Berco	23
Scutti	23
Service	24

LOW PROFILE FEEDER



Reversible Feeding

Transmin's Low Profile Feeder™ (LPF) is the original hybrid feeder delivering the advantages of both belt and apron feeders, plus additional benefits over conventional feeder technology that are unique to Transmin.

LPF capacities vary according to application, although rates of 10,000tph are possible. The LPF is built with trusted components, proven in the most arduous applications and with a low ongoing cost of ownership.

The LPF has the unique ability to incorporate a bend transition, which means a change of direction from horizontal to 25° inclined can be achieved without the requirement of a second machine; resulting in improved space utilisation, flexibility of plant layout and elimination of transfer points between conveyors, thereby reducing civil costs.





Less Spillage



Miss Tracking Eliminated



Belt Slippage Eliminated



Lowest Possible Profile

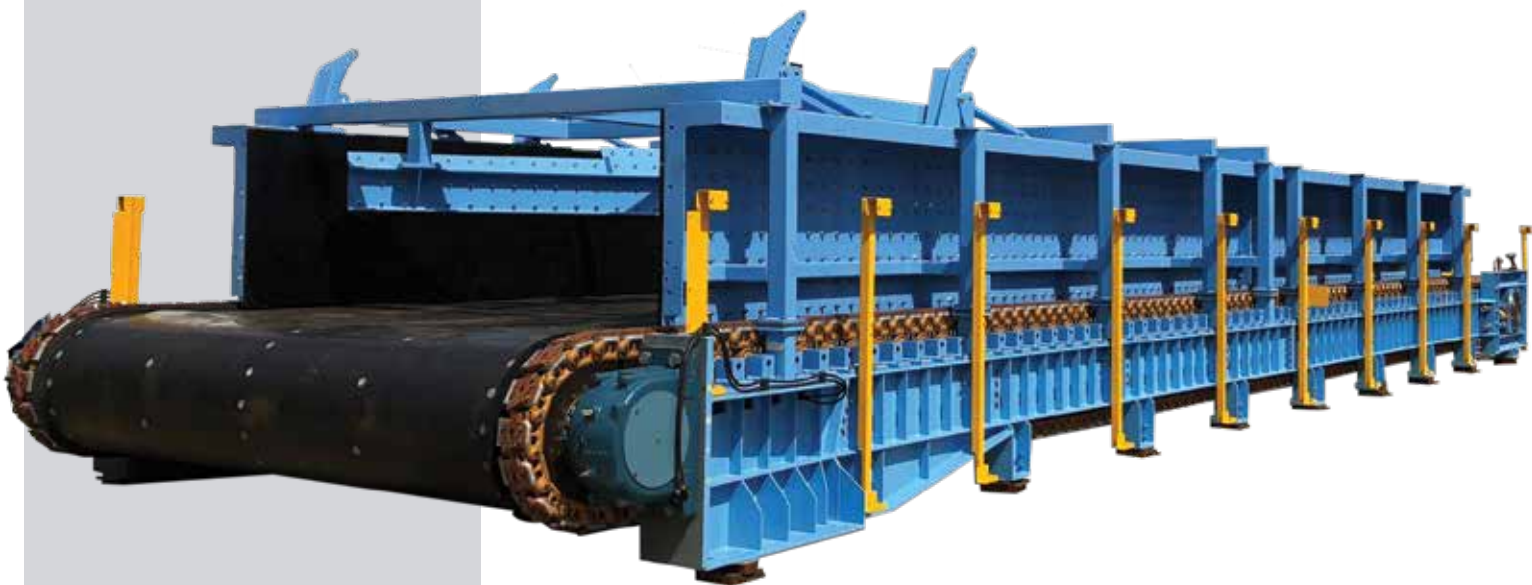

FEATURES

- ▶ Lengths up to 56m
- ▶ Incline angles up to 25°
- ▶ Belt widths up to 4.0m
- ▶ Weighing of material in transit
- ▶ One sided belt fastening
- ▶ Reversing capability for discharge at both ends
- ▶ Numerous installations around the world

TYPICAL INDUSTRIES

- ▶ Mining and mineral processing
- ▶ Ports
- ▶ Cement and building products
- ▶ Recycling and waste processing
- ▶ Power generation
- ▶ Fertiliser and chemical

MATERIALS

- ▶ Various ores
- ▶ Iron ore, tailings and stockpiled ores
- ▶ Coal
- ▶ Fertilisers
- ▶ Metallic concentrates
- ▶ Filter cakes
- ▶ Wood chips
- ▶ Cement clinker
- ▶ Sewage sludge
- ▶ Refuse
- ▶ Biomass
- ▶ Construction wastes
- ▶ Aggregate

“In fairness, the machine was used above and beyond its initial design spec and it’s never missed a beat. This thing is bullet proof.”

STUART TAYLOR, Karara Project

BELT FEEDERS



Since inception in 1987, Transmin has been designing and supplying bespoke belt feeders for mining and general industrial applications. In the early days these were mainly medium duty machines which sometimes incorporated load cells to accurately control or monitor material feed to process.

Transmin belt feeder designs are safe to operate with simplified maintenance, they provide efficient materials handling and have optimisation options through

custom designs. They can handle coarse, dry ores to feed crushers or screens and also fine, wet filter cake material to feed transfer conveyors or directly into a truck.

Versatile applications where the belt feeders can be used include filter press discharge feeders with optional cake breakers, high capacity weighing applications screen feeding, reclaim hoppers, straight inclined feeding and surge bin feeders.

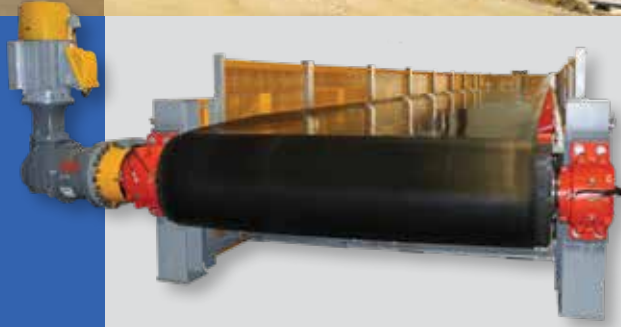

SELECTION DATA

STANDARD BELT WIDTH (mm)	EFFECTIVE SKIRTED WIDTH (mm)	NOMINAL CAPACITY RANGE* (m ³ /h)
750	500	270
900	600	400
1200	800	700
1600	1050	1240
2000	1350	1940
2600	1750	3300
3200	2150	4900

*Capacities in excess of 3500t/h are achievable, please consult Transmin direct. Capacities are calculated with a bed depth of two-thirds the skirted width and belt speed of approximately 0.5m/s.

Features & Benefits:

- ▶ **Head Enclosures**
Fully enclosed for safety and dust control, with access doors and mounting points for primary and secondary cleaners and option for dust suppression.
- ▶ **Drives**
Compact, shaft mounted drives with either planetary helical bevel combinations or hydraulic units.
- ▶ **Skirting & Liners**
Standard liners include BIS 400, Chromium Carbide Overlay (CCO), UHMWPE and other options upon request.
- ▶ **Guards**
Built to Australian Standards #AS4024. Guards are easily removable in manageable sections and can be fully enclosed. Pull wire switches, belt drift switches, belt rip detectors & block chute switches are all optional features that can be added.
- ▶ **Take Up**
Manual screw, as standard or hydraulic assisted belt tensioning systems an optional feature.
- ▶ **Custom Designs**
Various widths to suit most applications, with belt widths up to 3.2m. We can also include features such as cake breakers and dynamic weighing solutions.
- ▶ **Isolation Gate**
Transmin can design and supply an isolation gate to suit your feeder application.



APRON FEEDERS

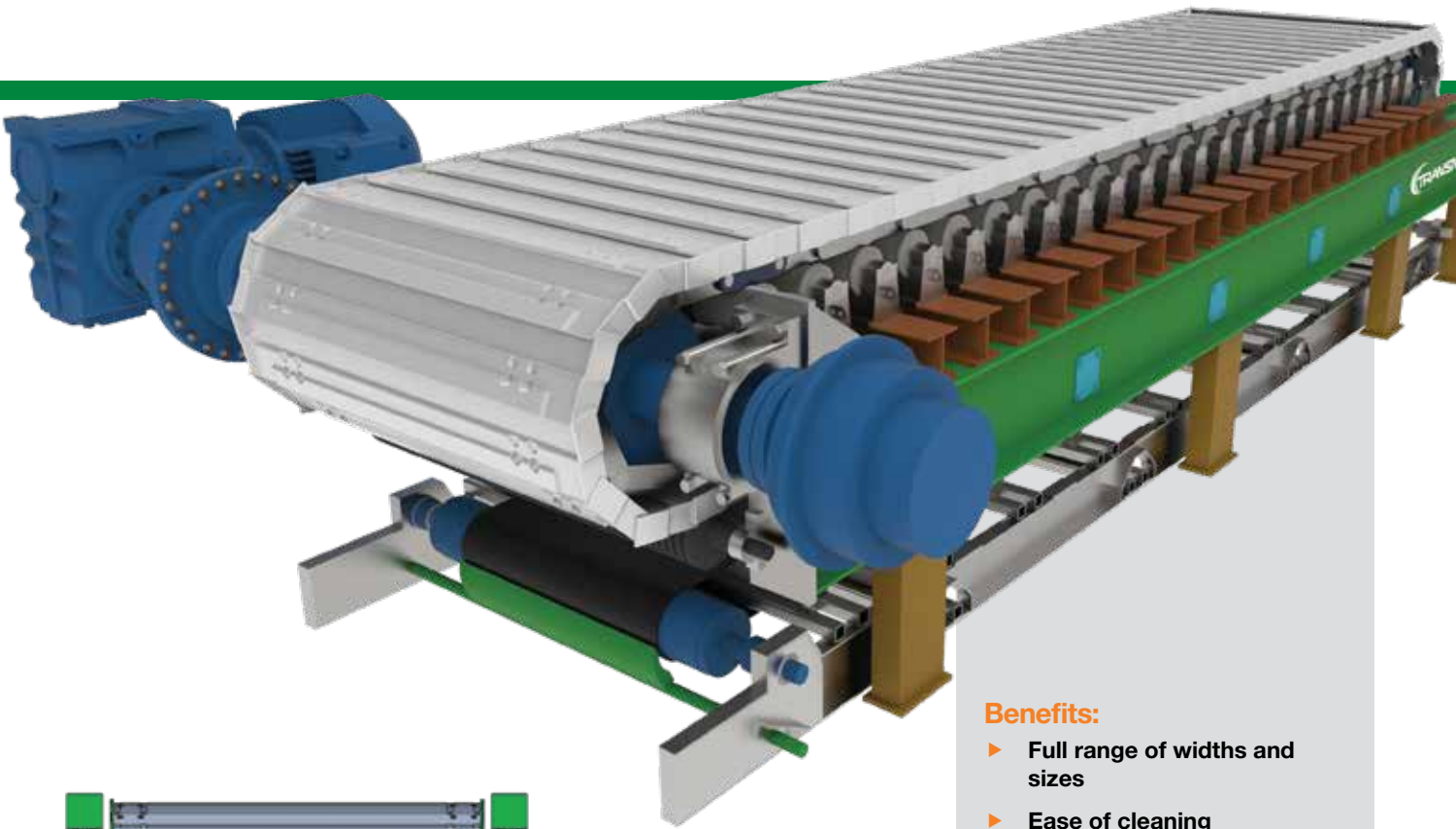

Benefits:

- ▶ Full range of widths and sizes
- ▶ Ease of cleaning
- ▶ Standard components
- ▶ Ease of roller extraction
- ▶ Full aftermarket support provided for parts and service

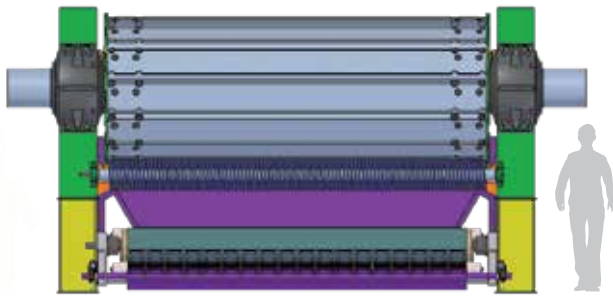

Transmin has introduced a range of conventional heavy duty apron feeders to complement the well-established and comprehensive range of Low Profile Feeders (LPF) which over recent years have become a technology of choice for feeder applications throughout the mining industry.

Key to the success of the LPF has been innovation and development. By listening to what the customers want from a feeder Transmin has been able to solve specific problems or achieve configurations not possible with other feeder technologies.

This approach has led to some of the most innovative feeder designs on the market today incorporating features such as swan neck configurations, 4.0m belt widths, machine lengths of 55m and tail mounted drives.

Once again Transmin has been listening very closely to customer feedback and in response to demand is introducing a heavy duty range of Australian Apron Feeders focused on applications such as high capacity primary crushing or ROM applications where D9 or D11 size is required at pan widths between 2.4m and 4.0m.

Being the Australian distributor for BERCO track chains and components, Transmin APFs use BERCO SALT chain, chain curtains and components such as sprockets, wheels and rollers.

A special design of pans is used to minimise material leakage on the return.

BED DEPTH (m)	THROUGHPUT (m ³ /hr)
0.3	716
0.6	1431
0.9	2147
1.2	2863
1.5	3578
1.8	4294
2.1	5010

BoomerHD ROCKBREAKER BOOMS



With many years of design evolution and experience in the world's largest grizzly and gyratory crusher applications, Transmin has enhanced its range of rockbreaking solutions to give customers a rockbreaker which is stronger, faster and has increased durability than previous models.

Made up of three models; 100, 130 and 160 Series* these rockbreakers are some of the largest rockbreakers in the world and are deployed in the toughest conditions imaginable. Engineered for large-scale mining and minerals processing plants, these rockbreakers offer longer periods between maintenance requirements and achieves lower life cycle costs.

* Larger 200 Series available on request.

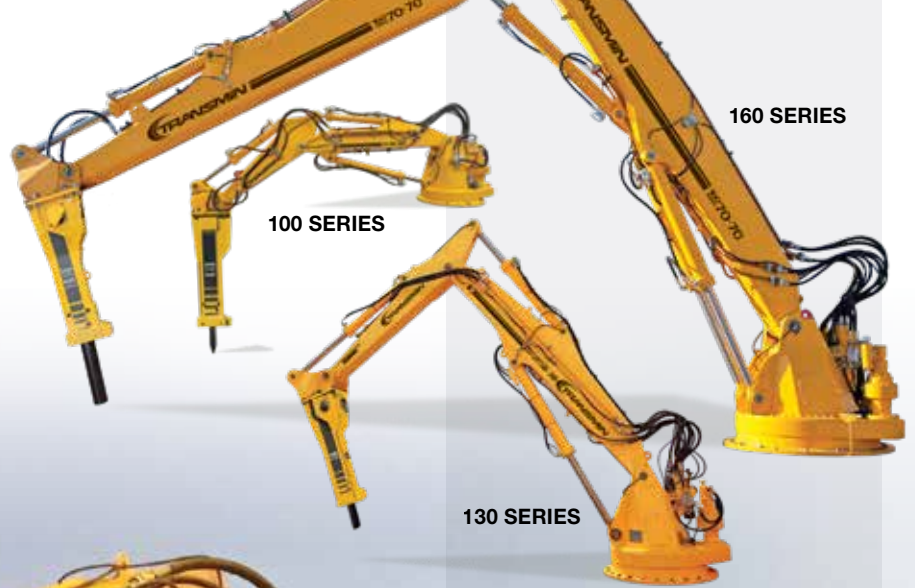

ROCKBREAKERS

- ▶ Suitable for all conditions; arctic, tropical, underground and high elevations
- ▶ Remote control available via the RockLogic automation package
- ▶ Recommended for use with Epiroc hammers however suitable for all hydraulic attachments
- ▶ Training packages available



100 Series

The Transmin 100 Series Rockbreakers are designed and manufactured to provide a strong, economical boom systems with heavy duty slew bearing for typical mining and quarrying applications such as jaw crushers and grizzly's.

100 SERIES	
Vertical Reach*	up to 6.9m
Horizontal Reach	up to 10.6m
Rock UCS	60~320MPa

* Hammer orientation vertical

MODELS	30-20	30-30	40-30	40-40
Horizontal reach from C/L of mount with hammer vertical (b)*	5.9m	6.9m	7.8m	8.8m
Maximum horizontal reach with hammer extended (c)	7.7m	8.7m	9.6m	10.6m
Vertical reach below base RL (d)*	4.4m	5.4m	5.8m	6.9m

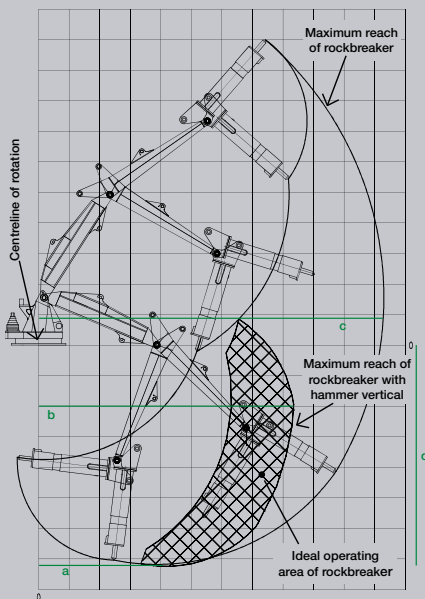
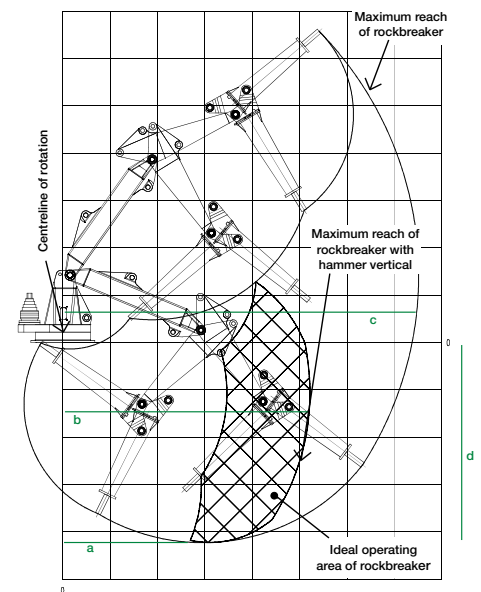

130 Series

The Transmin 130 Series Rockbreakers will take all that you can throw at them while delivering excellent performance. Placed over a large grizzly or crusher the Series 130 Rockbreaker will clear any blockages with ease.

130 SERIES	
Vertical Reach*	up to 8.7m
Horizontal Reach	up to 13.8m
Rock UCS	100~320MPa

* Hammer orientation vertical

MODELS	40-40	50-40	50-50	60-50
Horizontal reach from C/L of mount with hammer vertical (b)*	9.0m	9.9m	10.9m	11.9m
Maximum horizontal reach with hammer extended (c)	10.9m	11.8m	12.8m	13.8m
Vertical reach below base RL (d)*	7.0m	7.3m	8.3m	8.7m

160 Series

The Transmin 160 Series Rockbreaker comes with a standard 270°, or optional 360° slew, along with twin high strength planetary gearboxes. These huge machines make light work of the world's biggest gyratory crushers and grizzly screens.

160 SERIES	
Vertical Reach*	up to 11.8m
Horizontal Reach	up to 17.5m
Rock UCS	160~320MPa Plus

* Hammer orientation vertical

MODELS	60-60	70-70
Horizontal reach from C/L of mount with hammer vertical (b)*	13.1m	15.1m
Maximum horizontal reach with hammer extended (c)	15.1m	17.5m
Vertical reach below base RL (d)*	9.9m	11.8m

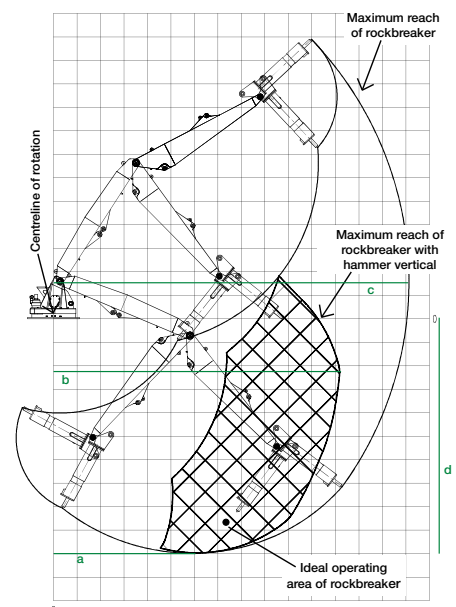



ROCKLOGIC

SAFE, INTELLIGENT ROCKBREAKER OPERATIONS

RockLogic is Transmin's intelligent anti-collision and control solution for rockbreakers, delivering safer, smarter, and more efficient operations. High-precision inertial sensors continuously track the rockbreaker's position and display it within a detailed 3D site model, enabling automatic speed control and collision avoidance.

With accurate real-time feedback, operators can safely control the rockbreaker remotely from the control room, eliminating unnecessary site travel when crushers become blocked.

Autonomous features such as automatic park and deploy routines ensure smooth, repeatable movements, even in tight and restricted spaces.



ROCKLOGIC FEATURES

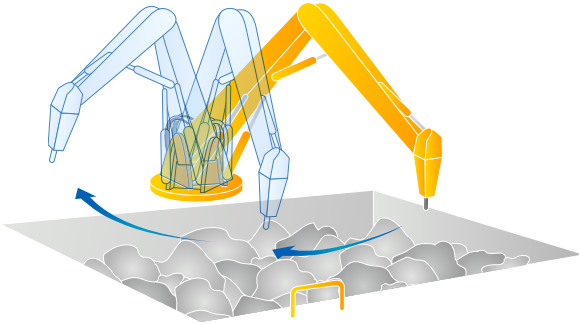

Automated Movement

Go from park to deploy and back to park with a press of a button – minimising crushing delays.

When operating Rockbreakers remotely, parking the rockbreaker is often a tricky maneuver, with one touch park and deploy the Rockbreaker simply puts itself away after clearing blockages.

Remote Operation

Rockbreaking is hazardous and demanding work. RockLogic remote operation moves operators away from the rockbreaker to a safe, remote location, reducing exposure to hazards and eliminating unnecessary travel. A bypass mode is included to support maintenance operations.

RockLogic enables operation from on-site control rooms, remote operation centers thousands of kilometers away, or via radio controller for site use. Operators can control up to four rockbreakers from a single desk (one at a time) using the slimline controller. An optional audio kit provides headset support with full audio feedback, improving efficiency and operator awareness.

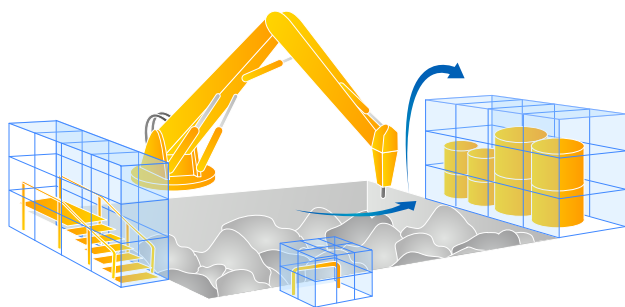

Collision Avoidance

Prevent unnecessary downtime with customized collision avoidance that protects the rockbreaker and surrounding plant equipment. Using 3D scans or CAD data, RockLogic models your site to create a collision scene that prevents contact with critical structures such as bin walls, handrails, camera posts, and crusher components—giving remote operators greater confidence when working via cameras.

Plant, Process & Safety Integration

RockLogic seamlessly integrates with plant control and safety systems to maximize throughput while reducing risk. Signals from vehicles and plant equipment automatically retract the rockbreaker to support continuous crushing operations, minimizing delays and improving long-term productivity.

Integrated safety features includes machine shutdown systems, safety gates, emergency stops, and slew-limiting proxies help protect personnel and equipment. All rockbreakers come with a SIL2 capable safety system that can be tuned to site requirements.

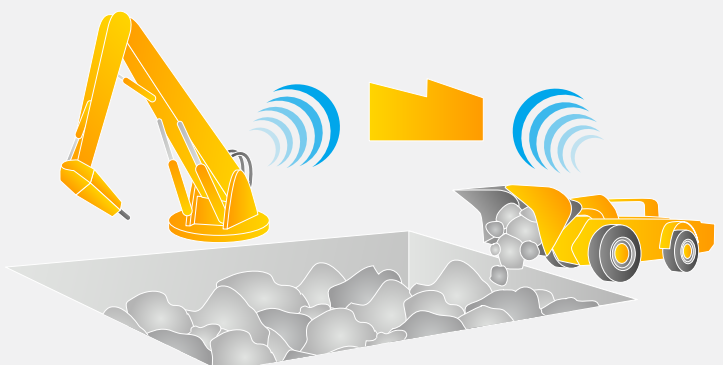

BIN ISOLATION GATES

Developed primarily for the needs of the iron ore industry, Transmin designs and manufactures some of the largest bin isolation gates in operation with opening apertures up to 12.0m long by 3.0m wide and materials after the primary crusher.

Most designs feature hydraulic operation using Transmin in-house designed cylinders and hydraulic power units. In addition, electric and pneumatic actuation has been supplied on the more lightly loaded duties.

Transmin also has the capability to design special gates including single or double clam shell type gates, diverter or traveling gates.

SINGLE OR DOUBLE SLIDING PLATES

Dependent upon the size of the aperture to be isolated, Transmin designs feature either a single-gate plate or double-gate plates, closing from each end and overlapping in the center.

Gates over approximately 3m long will utilise double plates to optimise the cylinder size to isolate even the largest apertures.

WEAR LINERS

Wear liners are fitted for maximum durability and to protect the high wear edges and changes in direction of material flow.

FEATURES

- ▶ **Complete Isolation Safety**
Isolation gates are primarily fitted to safely isolate downstream equipment such as Low Profile Feeders, belt feeders, screens and apron feeders, so they can be removed or worked on during maintenance site campaigns.
- ▶ **Hydraulic Power Units**
Unique hydraulic power packs with simple local control panels can be built to Transmin or client specifications.
- ▶ **Diverse Custom Options**
Transmin can customise our range of gates to suit a myriad of applications including diverter or high capacity flow conditions of aggressive materials.



APPLICATIONS

Primary applications include stockpile outlets, dump hoppers and screen feeding bins.

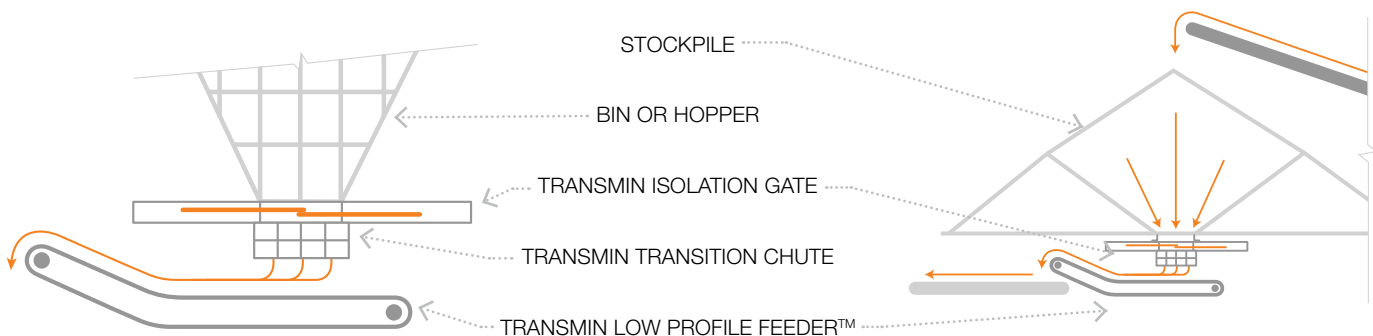



Diverter Gates



Local Operator Panel

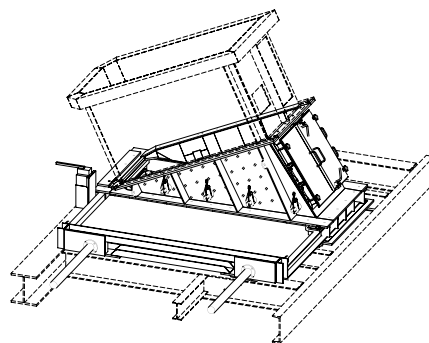

Maintenance Gates

Designed as a platform to allow maintenance personnel quick and safe access for maintenance such as high wearing areas in chutes.

Hydraulic Power Units



LIME MIXING & DOSING PLANTS



Since inception in 1987, Transmin has been designing systems to handle, store and process lime products, predominantly to the gold, minerals processing and water industries.

We are the largest specialist supplier of lime plants in Australia. 100's of successful installations have been completed in Australia and Overseas.

Generally, customers will be using hydrated or quicklime (Calcium oxide) within their process to control pH. Transmin has supplied numerous installations from simple lime silos to complete turnkey lime slaking facilities.

We have developed a range of efficient cost effective slaking systems comprising of roller mounted ball mills Classification is carried out where necessary by cyclones included within the circuit.

A full turnkey service is available from concept development through design, manufacture, installation and commissioning including electrical controls and civil works.

In addition to supplying systems for lime, Transmin has also successfully adapted the concept for cement, dolomite, soda ash, magnesium oxide and other mineral powders and reagents.

BENEFITS

- ▶ **Processing**
Slaking and grinding mills of the roller mounted or vertical type. Grind performance to suit client process requirements.
- ▶ **Receival**
Intake of lime via bulk bag or pressurised vehicle.
- ▶ **Storage**
Single or multiple silos dependent upon site storage requirements.
- ▶ **Wetting**
Pre-wetting prior to mill for control of dust.
- ▶ **Limestone**
Separate limestone grinding facilities available.
- ▶ **Milk of Lime Storage**
Tankage is either site built or supplied complete.



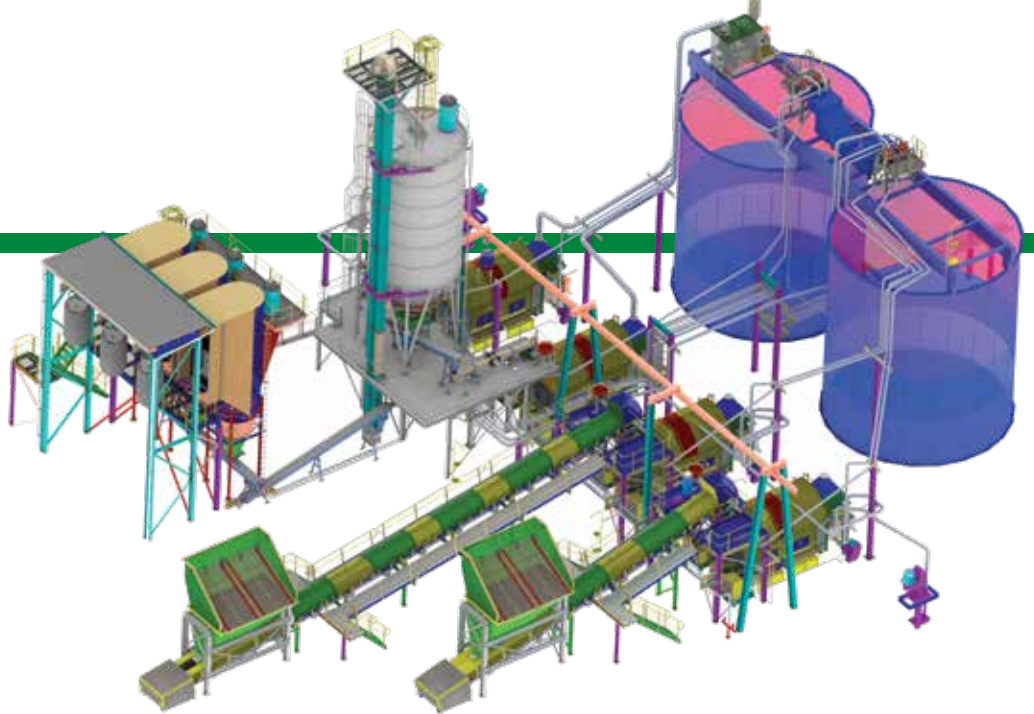

Hydrated Lime Mixing Facilities

Simple and cost effective, Transmin has a range of components available to custom design a hydrated Lime Mixing Plant to meet any requirement.

Depending on the system capacity and the preferred method of storage, the system can accept product from pressurised road tanker or bulka-bag, with total storage capacity to suit the plant's individual needs. Transmin's extensive range of bag breakers, pneumatic transfer systems and pre-wetting units will ensure reliable trouble free operation.

High accuracy mixing can be achieved using loss-in-weight or weigh screw feeder systems to dose the lime in to the slurry mixing tank.



Full Lime Slaking Plants

For those installations requiring a greater production of Milk of Lime (MOL) a complete Lime Slaking Plant may be the preferred option. These systems will typically receive quicklime from a pneumatic road or rail tanker and total site storage can range from fifty to several thousand tonnes of dry quicklime.

The dry product is automatically metered into the Lime Slaking Ball Mill by the integrated PLC control system. This system maintains the water set point and adjusts the feed rate of quicklime to maintain an efficient Slaking reaction temperature. Depending on site requirements, either an open or closed loop grinding system can be offered.

As part of the package, a full compliment of agitated mixing, storage and ageing tanks is available, complete with transfer pumps, piping, valving and level control instrumentation and monitoring. An option for automatic MOL pipeline flushing is also available.

High efficiency pre-wetting units and fume extraction scrubbers are a standard feature of all Transmin Ball Mill slaking plants.

Other Lime Applications

- ▶ Flue Gas Desulphurisation (FGD) lime dosing systems.
- ▶ Dry lime dosing onto Mill Feed Belts for pH control.
- ▶ Heap Leach MOL dosing for pH control.
- ▶ Calcined lime grinding, conveying and storage systems for lime manufacturers.
- ▶ Large capacity lime ageing tanks.
- ▶ Sea container unloading facilities - separate brochure available.
- ▶ Limestone feeding, grinding & mixing systems.
- ▶ Water treatment pH Control.
- ▶ Waste water treatment neutralisation.

Roller Mounted Ball Mills

Transmin Roller Mounted Ball Mills are a low cost, easily installed and maintained solution for many small capacity wet grinding operations. Designed for either closed or open circuit grinding.

Also available is the new Trunion drive model with a simplified drive mechanism incorporating a Trunion ring on the front face.

F80 = 2mm P80 = 75µm		
MILL MODEL	STANDARD DRIVE (kW)	QUICKLIME AVERAGE THROUGHPUT (t/h)
1.0 x 1.5	11	0.45
1.2 x 3.0	45	2.0
1.6 x 3.6	90	5.5
1.8 x 3.6	132	8.0
2.0 x 4.0	132 + 75 [#]	12.0
2.2 x 4.4	185 + 75 [#]	18.0

*Other sizes/duties are available upon request.
[#]Primary and secondary drive sizes.

FLOCCULANT MIXING SYSTEMS

Flocculant preparation has been a mainstay of Transmin's business and extends to multiple reagent systems including guar, starch, depressant, coagulant and frother preparation systems. Transmin has experience in the preparation of liquid solutions for reagents such as soda ash, magnesia, ammonium sulphate, fluorosilicate, xanthate, PAC and other liquids.

Transmin's bulk material handling expertise and the technical knowledge of some of the world's largest manufacturers of polyacrylamide flocculants, has resulted in the development of a range of fully automated Polymix flocculant preparation systems.

Each system has identical standardised control and mechanical design philosophies with changes in tank and equipment sizes and capacities. This high degree of standardisation reduces delivery lead times and allows for optimised spares inventory support.

Utilising this knowledge gained on Polymix systems, Transmin has expanded its range from 4kg/h throughput all the way upto 472kg/h throughput. These high capacity systems are used for the treatment of large volumes of tailings generated by mines.

The high throughput systems can utilise large capacity storage silos filled by bulk tanker truck delivery. Capacities for silos are often chosen for 7 or 14 days worth of dry polymer storage.

Further to dry storage, storage of the mixed polymer solution is done in large capacity tanks, usually sized with 6 to 12 hours of storage capacity.

Other storage durations can easily be accommodated, depending on customer preference.

FEATURES

- ▶ Simple modular construction and efficient design ensures easy maintenance, fault finding, parts replacement and reliable operation.
- ▶ Heated Cone within dry feed system ensures flocculant powder is suitably dry to ensure efficient pneumatic conveying to wetting head.
- ▶ Automated control with minimal operational involvement other than loading bulk or single bags into the storage hopper at pre-set frequencies. Larger systems use tanker truck fed silos.
- ▶ Remote monitoring of system is easily connected.
- ▶ Safe and easy hopper loading bag breaker with bag loading bay and access ladder to the hopper inlet.
- ▶ Sensible layout and design results in minimal splashing of flocculant solution, with platform layouts



VOLUMES			
MODEL	FLOCCULANT THROUGHPUT (kg/h)	MIX TANK (m³)	STORAGE TANK (m³)
Polymix 1000	4	1	2
Polymix 2000	7	2	4
Polymix 4000	11.5	4	8
Polymix 5000	18	5	18

**Larger sizes/duties are available upon request.*

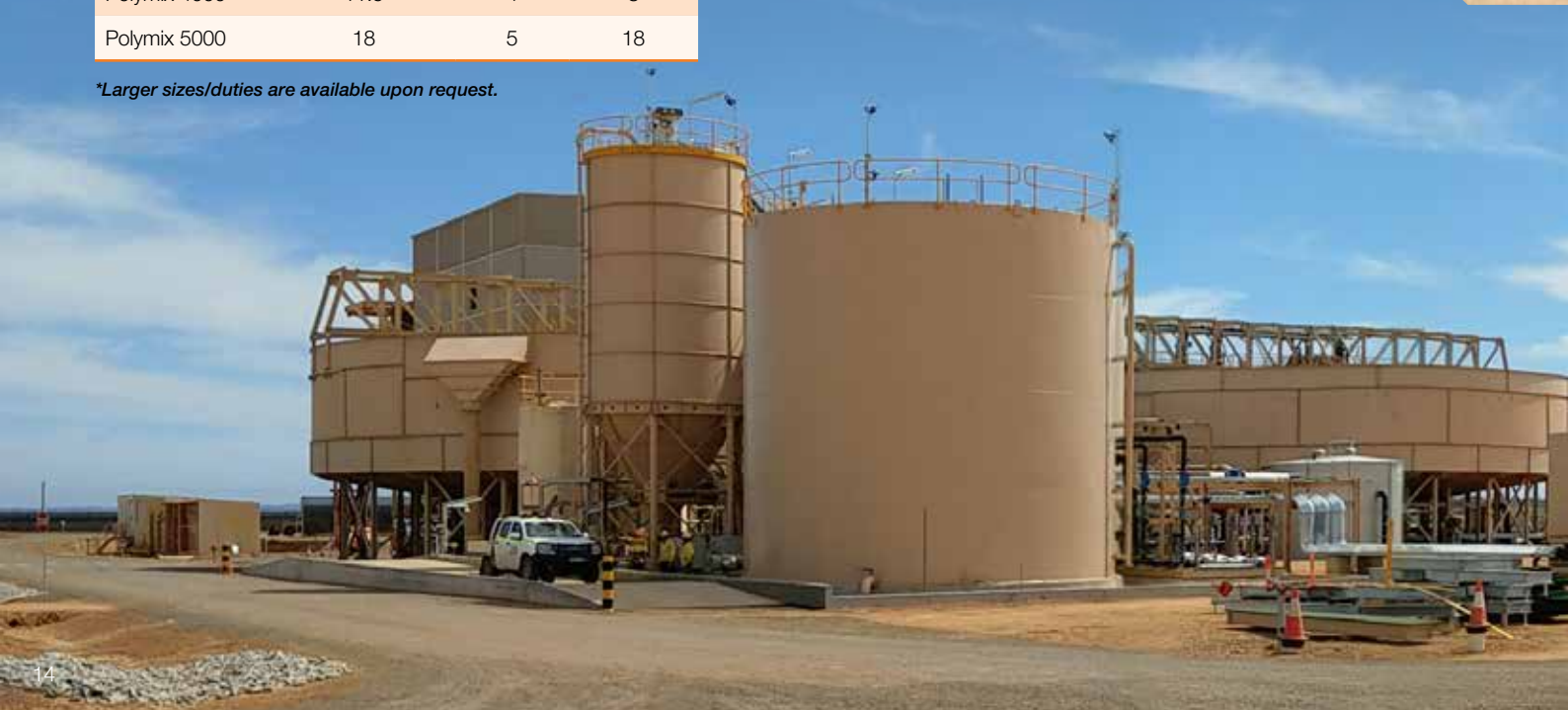

enabling an easy and safe wash down for tank surfaces. Efficient spatial design of system ensures minimal plant footprint.

- ▶ All mechanical equipment is sufficiently rated for external operation, and is sufficiently shrouded from wash down.
- ▶ Optional flocculant dosing pumps and control packages with dry run protection if required.
- ▶ Polymix control panel positioned on the flocculant access platform as an integral part of the modularised package, providing easy access and observation of system control.
- ▶ Simple external operator adjustments for required process control exist on the main control panel as well as a fail-safe emergency stop facility.
- ▶ Blower ducting is joined by simple couplings for flexibility of installation and easy pipe removal for maintenance and cleaning.



BALL CHARGING & GRINDING MEDIA HANDLING

Transmin has a range of systems available to safely store and feed balls from simple kibbles through to complex handling systems comprising of storage hoppers connected to ball feeders of the cassette or 'star feeder' type. These devices can feed directly into mill feed chutes or conveyors which are often the most cost effective solution.

For larger plants we incorporate side wall 'pocket belt' conveyors to elevate the balls within the plant and then transfer to flat belt conveyors incorporating multiple mill feed stations in the form of pneumatic ploughs and gates to feed multiple mills on demand. Recent projects have included feed conveyors over 100m long with up to five outlet ploughs.

COMPLETE BALL HANDLING SYSTEMS

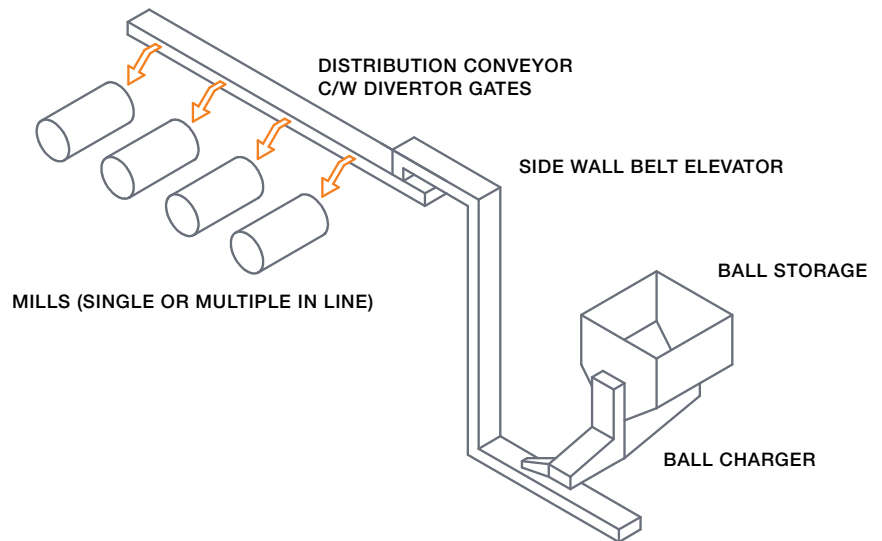

BENEFITS

- ▶ **Standard Design**
Transmin has four standard designs that are safe and compact to use with FEL, drum or bags of balls.
- ▶ **Self Clearing**
A self clearing mechanism is utilised to prevent jamming of balls.
- ▶ **Meter Rate**
The capability to infinitely vary the ball metering rate.
- ▶ **Alarm Facility**
The ball chargers feature an alarm facility to indicate feeder empty or blocked chute.
- ▶ **Modular Construction**
Designed in modular sections comprising storage hopper, kibble chute and either slot or star feeder means all duties can be accommodated.
- ▶ **Weighing System**
Balls of any size are accurately weighed during the operation with feed controlled by the plant command center.

BULK STORAGE SILOS

Transmin offers a large, diverse range of silos and bins to suit any application handling materials, including; fly ash, bitumen, cement, quicklime, hydrated lime, flocculant, talc, aged lime, flour, salt, sawdust, magnesium oxide and sugar. Each silo system is designed and engineered to produce maximum efficiency and discharge for each particular process.

Transmin also offers turnkey packages incorporating Transmin designed silos or bins, together with mechanical equipment for feeding and/or discharging stored product.

Fabrication materials include mild steel, stainless steel, concrete, fibreglass and bisalloy. Transmin have successfully supplied and installed silos, bins, hoppers and storage tanks ranging from two cubic meters up to 3000 cubic meters holding capacity.

Whatever the situation, Transmin can engineer the solution.



SPECIAL PRODUCTS & PROJECTS

Roller Mounted Ball Mills

Transmin Roller Mounted Ball Mills are a low cost, easily installed and maintained solution for many small capacity wet grinding operations. Designed for either closed or open circuit grinding.



F80 = 2mm
P80 = 75µm

MILL MODEL	STANDARD DRIVE (kW)	QUICKLIME AVERAGE THROUGHPUT (t/h)
1.0 x 1.5	11	0.45
1.2 x 3.0	45	2.0
1.6 x 3.6	90	5.5
1.8 x 3.6	132	8.0
2.0 x 4.0	132 + 75#	12.0
2.2 x 4.4	185 + 75#	18.0

*Other sizes/duties are available upon request.
#Primary and secondary drive sizes.



Circle Feeder

When difficult materials need to be discharged from bins and hoppers to a number of outlet streams, the circle feeder becomes a viable option.

Bin Activators

Transmin has a standard range of vibratory bin activators from 914mm diameter to 3660mm diameter, plus the capability of designing bespoke models for difficult materials or odd sizes. The unit shown is 3,660mm diameter and is fitted to a large lime silo at a nickel processing plant.



Loss-in-weight Feeders

The continuous loss-in-weight (LIW) principle involves weighing the entire feeding system (hopper, feeder and bulk material) by means of a static type scale system, and controlling the discharge feed rate of the bulk material by means of a variable speed motor. Material is discharged from the system via screw or rotary feeder, with the measured "loss in weight" per unit time (dv/dt) compared to the desired (set) feed rate. The hopper is then quickly recharged (manually or automatically), and the loss-in-weight control action repeats. The fill rate of the LIW system should be typically 10 to 15 times greater the targeted discharge rate.

VALUE, EXPERIENCE & TRUSTED SOLUTIONS

Transmin with its 30 years of proven bulk material handling machinery builds, has become a respected Australian owned company that can work with you to make your project run smoothly on time and budget.

With support from engineering, drafting, parts supply and our maintenance staff that have hands on experience from building the equipment from the ground up, though to continuous improvement programs to grow with changing needs and technology improvements. Transmin is looking toward the challenges of the next 30 years.

AFTERMARKET AGENCIES



ConveyorPro



ConveyorPro EVERYTHING CONVEYORS

Meet ConveyorPro, the ultimate conveyor solution from Transmin. Backed by 30 years of trusted industry experience, ConveyorPro brings components, installation, maintenance and engineering expertise together under one roof.

From belting and pulleys, to scrapers and guarding, ConveyorPro delivers everything you need to keep operations running smoothly, efficiently and without compromise.

With a strong commitment to safety, reliability and efficiency, ConveyorPro has earned a reputation for high-performance conveyor solutions tailored to each operation. From concept through to ongoing support, ConveyorPro is your trusted partner in end-to-end conveyor performance and innovation.

THE COMPLETE RANGE

- ▶ Belt including ProTough, ProEdge, Sidewall
- ▶ Idlers and rollers including composite rollers
- ▶ Pulleys and lagging
- ▶ Guarding - GuardlitePro
- ▶ Belt cleaners, scrapers, trackers
- ▶ Impact beds
- ▶ Skirting Systems
- ▶ Belt tooling, belt lifters and cutters
- ▶ Mechanical splicing kits and hot vulcanisation kits

WHY CONVEYORPRO?

- ▶ Brought to you by Transmin – an industry leader for nearly 40 years
- ▶ End-to-end service:
 - ▶ Designed in-house in Malaga, WA
 - ▶ Site-support – installation, maintenance, inspections, reports
- ▶ Competitive pricing
- ▶ One-stop-shop with a comprehensive range
- ▶ Strict quality control: ITP's, MDR's, full traceability
- ▶ Global presence with local partners
- ▶ Stocking arrangements available

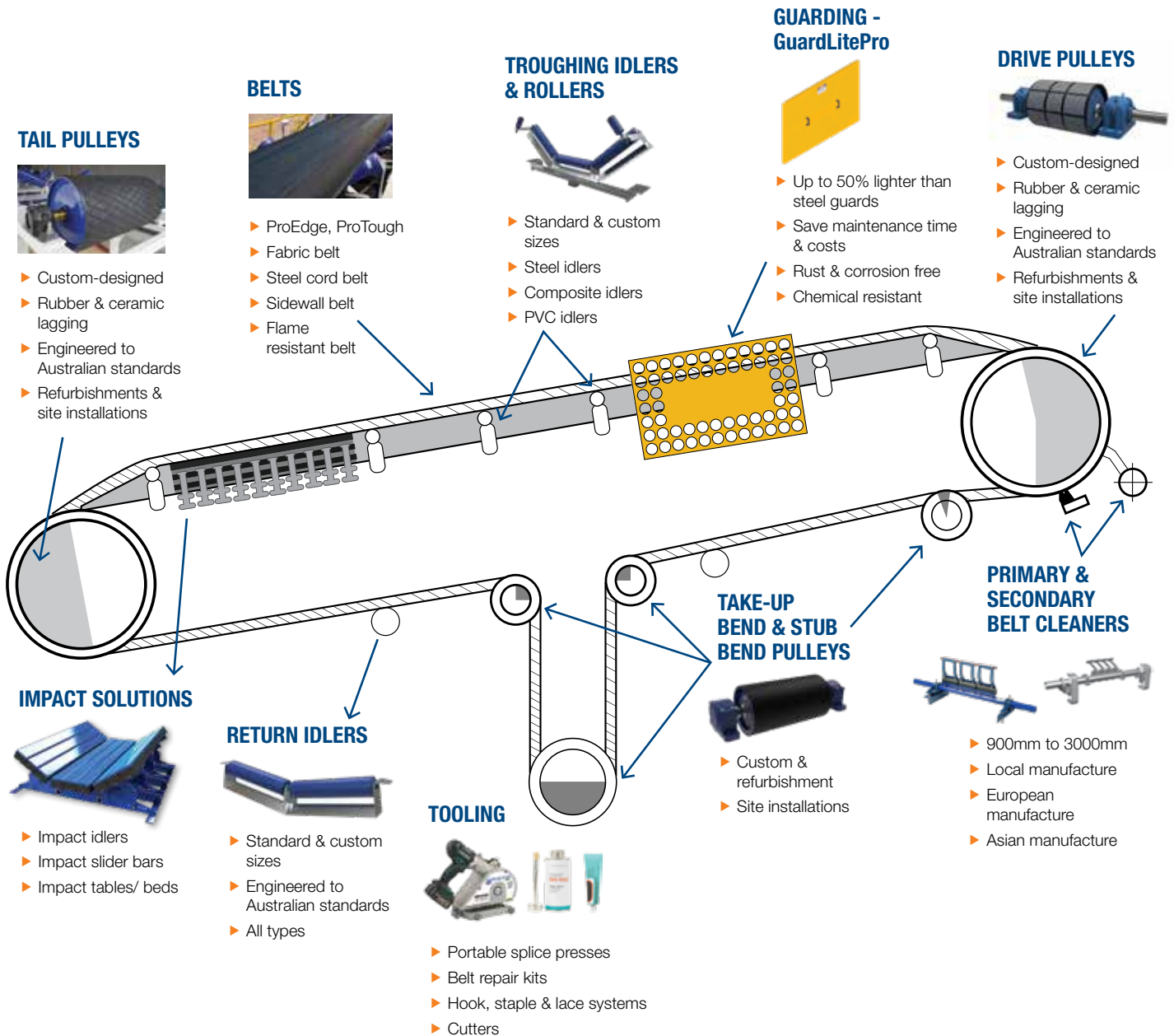

Transmin and Martin Engineering have teamed up, bringing together over 100 years of industry experience. Martin Engineering have manufactured durable products that helped customers globally, handle bulk materials efficiently since 1944, safely and profitably.

BELT CLEANERS

Martin Engineering, offers belt cleaners that work with all belt sizes and speeds, regardless of industry or type of material. We also offer belt cleaners that work in the most challenging and unique environments, such as on conveyor systems where there's minimal space around the head pulley.

Our specialty belt cleaners include conveyor belt washing systems, belt brush cleaners, food-grade belt scrapers, water cleaners and high-temperature cleaners, all engineered for challenging conditions and unusual materials.



IMPACT BEDS

Martin Engineering's impact beds absorb the force of falling material at transfer points, minimising damage and excessive wear to the belt and structure.

This also cuts down on fugitive material and runaway dust, which can cause substantial health and safety hazards. Our belt support products also eliminate pinch

points where trapped material can gouge the belt and over time, compromise its structural integrity.

Martin's impact beds are available to support a range of belt widths and can even be customized to accommodate unique conditions when necessary.



SKIRTING SYSTEMS

Martin Engineering's belt sealing solutions include skirting products that ride on the belt and self adjust to maintain an effective seal without regular maintenance. We also offer wear liners that shield the sealing system from the material load, prolonging the life of the seal.

These products are engineered to minimize fugitive dust and fine particulates from escaping the belt. Our belt sealing products are available for troughing angles ranging between 0 and 45 degrees. Plus, the compact design enables installation with as little as 1¼ inch of free space on each side of the belt.

Since, 1920, Berco have been an established name in track and undercarriage chain. High-quality materials and careful manufacturing processes ensure that Berco undercarriage components are reliable, durable and wear at a predictable rate. Longer life and controllable wear mean that you achieve maximum undercarriage performance at the lowest operating cost. Berco call it “Best Undercarriage Value”.

BPR₂ BENEFITS

Mining Lubricated Chains

Performance upgrade of the BERCO product for large mining CAT* crawler dozers D8 to D11 and large fix plant feeders.

- ▶ The BPR2™ system uses a metal ring plastically deformed as a mechanical locking element. This ring is pressed into the groove between the pin and the link, blocking the joint to specific predetermined end-play levels.

- ▶ Completely new and improved seals, designed by Berco with materials suitable for extreme working temperature range.
- ▶ Optimised pin grants increased link interference and track robustness.
- ▶ Carburized bushing with improved geometry to extend track life.



SCUTTI

Scutti, was established in 1967 by Mr. Nicola Scutti, the company's early days were spent in focusing on manufacture of silos for cement throughout the European market place. During the following years the company has been characterised for harbour silos and dry bulk storage solution.

BULK STORAGE SILOS

Scutti has a large selection of standard silos ranging from 20 to 3000m³. Silo structures are designed to EUROCODE 3 Part 4-1 standards, to ensure compliance and safety with each seismic and wind requirement. Options include silo safety devices, dust collectors and screw conveyors.

SCREW CONVEYORS & FEEDERS

Screw conveyors for dry powders, available in different sizes with tubular or U Trough design. The wide range of heavy duty components allow the installation of Scutti screws conveyors in many industrial fields.

DUST FILTERS

Scutti dust collectors are available in a wide range of models and capacities and are recommended for dry inactive powders. The cleaning system is available by air or mechanical vibrating system with static or dynamic execution.



SERVICE

ONSITE/OFFSITE CAPABILITIES

Transmin's dedicated and highly trained service division supports materials handling operations worldwide.

Regular servicing for your equipment is the best way to ensure that your equipment performs efficiently and goes the distance in the harsh environments they work in to maximise your investment and avoid expensive unplanned downtime.

Transmin can play an active role through the life of your machinery from installation, commissioning, preventative/ongoing maintenance, troubleshooting, design, and process change upgrades, rebuilds to decommissioning and replacement with new Transmin equipment (some of our original equipment is still being serviced by our technicians after 25 years of service).

Transmin provide comprehensive servicing of both Transmin and third party OEM equipment. Provided is a range of site maintenance and plant optimisation services, including:

- ▶ Shutdown and breakdown maintenance support
- ▶ Preventative maintenance planning and execution
- ▶ Inspections and field audits
- ▶ Engineering support services
- ▶ Technology and design upgrades
- ▶ Major equipment overhauls and refurbishments on site and in our workshop

Transmin can accommodate a variety of site equipment in our purpose-built facilities based in Malaga, Western Australia. Our large fully equipped workshop is suitable for heavy assembly and fabrication with dedicated servicing and testing of mechanical and hydraulic equipment.

Transmin Service staff are also highly experienced in field maintenance, installation and commissioning for when it makes more sense to bring Transmin to the machine.

The range of equipment we service includes:

- ▶ Apron and belt feeders
- ▶ Conveyors
- ▶ Screw drag chain conveyors
- ▶ Hydraulic boom systems
- ▶ Sizers
- ▶ Lime mixing systems and flocculant plants
- ▶ Bin isolation gates
- ▶ Bucket elevators
- ▶ Scales
- ▶ Automation services
- ▶ Ball mill service and relines
- ▶ Ball mill ball chargers
- ▶ HPU Systems



APRON FEEDER CAST ALLOY PANS

Transmin's range of custom manganese steel apron feeder pans can improve your pan life, saving down time and improving run life. Cast for exact fit and tolerance, these pans are easy to fit every time using either our standard sizing or are custom made to fit your existing design and engineering specifications. Combined with our Berco range of chains, undercarriage parts and specialist feeder maintenance teams, Transmin offers a scaled up range to your feeder rebuild and part requirements.

APRON FEEDER SERVICING

Transmin has been servicing and rebuilding feeders since the early 1990's, putting us on a world stage with our equipment in every corner of the globe. With this history, we have built a wealth of knowledge in every aspect of these machines from our specialist technicians

on the front line trouble shooting, to engineering drafting and parts supply.

Our team of onsite servicers are trained and experienced for every level of feeder maintenance. From maintenance audits and alignments to full shut teams for ground up rebuilds including gantt and time line support, for all brands and makes of feeders.

Transmin is a distributor for Berco chain and under carriage parts as well as our own line of cast alloy pan liners that can be custom made to suit any arrangement configuration or engineering specification.

ISOLATION GATE REFURBISHMENT

Transmin designs and fabricates single-plate and double-plate isolation gates for safely isolating downstream equipment such as screens, feeders and conveyors so they can be removed or worked on during maintenance site campaigns.

Transmin's onsite servicers are trained and experienced for every level of refurbishment from fixing minor leaks to full back-to-bones strip down and replacements.

SERVICING & ROTABLE HYDRAULIC CYLINDERS

With Transmin designing and fabricating machinery for over 30 years, our experience in coming up with the best way to refurbish and restore equipment has become part of our story.

Our highly knowledgeable team at Transmin repair and refurbish hydraulic cylinders including: re-chroming, machining and replacing rods and seals.

All repairs are carried out to OEM standard, giving you as close to new as possible.



"Yes, I would recommended Transmin to other business and colleagues. I continue to use Transmin for not only feeder work and spares, but also for our crusher and conveyor spares."

CHARLIE GROAT

SHUTDOWN PLANNER
NORTHERN STAR RESOURCES,
KANOWNA BELLE

COMMITMENT TO SAFETY

Transmin was a finalist in the WA WorkSafe Awards in 2014 and 2015.

Transmin is committed to achieving a high standard of workplace health and safety, including mental health and well-being. Our aim is to prevent personal injury and/or harm by creating and maintaining a safe, healthy and productive working environment for all our employees, clients, contractors and sub-contractors.

EXPERTISE & EXPERIENCE

Transmin is a leader in engineered solutions for bulk materials handling and processing for the mining and minerals industries throughout Australia and internationally. With more than 30 years of experience, Transmin sets the standard in innovative mechanical equipment design and application. This expertise together with our full engineering and fabrication capabilities enables us to offer you the right service for your equipment.



AUSTRALIA

Local Call: 1300 127 091

International Call: +61 (0) 8 9270 8555

A: 33-37 Denninup Way Malaga, Perth, Western Australia, 6090

E: info@transmin.com.au



www.transmin.com.au