



Case Study:

TWO IDENTICAL D9, 46m LONG LOW PROFILE FEEDERS

AUSTRALIA

Location:
Pilbara region,
Western Australia

Operation Type:
Magnetite Iron Ore

Equipment Solution:
Low Profile Feeder

Year:
2021

Scope of Project:

A new joint venture project has been established, in the Pilbara region of Western Australia to deliver high concentrate magnetite ore at low operating costs.

With life expectancy of 20 years, the mine is expected to produce 22 wet million tonnes per annum (wmtpa) of magnetite ore, making it the largest magnetite mine in Australia. The ore will undergo two stages of crushing, then it will be ground to fine particles suitable for wet magnetic separation. The magnetite concentrate slurry will then piped to the port.

The Low Profile Feeder (LPF) was selected by the client due to its unique ability to act as both a feeder

and conveyor in the same machine. This allowed the client to remove the requirement of a conveyor after the feeder. In addition to this, the low belt height allowed the overall height of the crushing station to be lowered.

The Solution:

Transmin's brief was to engineer, manufacture and assembled two identical 2.6m wide heavy duty LPFs, to be housed under the primary crusher.

Magnetite iron ore from the primary crusher is discharged onto the LPF at the tail end through a hopper, then conveyed along the 15° inclined section of the feeder to the head end, making the feeders each 42m in length, between centres. The ore is discharged out of the head cover to downstream plant equipment.

These Low Profile Feeders (LPFs) tip the scales at over 230 tonnes each!

Designed to withstand impact loads from falling rocks from above and feed rate of 5,600t ph each LPF is capable of starting under any load conditions including full load and operating in fully automatic, unmanned control.

Both feeders use twin gear-motors, with a combined rating of 710kW. They share the same head shaft, one on each side. These drives are controlled in parallel meaning that all interlocks and safety cut offs apply to both at the same time. The drive speeds are also linked, meaning it

is impossible to run one faster than the other.

Light weight guards have been designed to focus on safety while meeting Australian standard requirements. By reducing the overall weight for each guard by 40%, makes them easier to handle and secure, reducing overall maintenance time.

Transmin's Aftermarket conveyor brand, ConveyorPro supplied the 2.6m wide conveyor belt with edge strip, ProEDGE. The benefit of ProEDGE, is with its hot vulcanised edge strip, the bond strengths between the edge strip and the belt are strengthened, therefore increases

wear life, reduces maintenance and product spillage.

Berco D9 SALT (sealed and lubricated track) chain was selected for its robustness and proven track record in this industry. Transmin is also able to support the Berco product effectively due to the fact Transmin is the sole Berco agent in Western Australia.

Transmin's inhouse Quality Control team ensured that the steelwork, fabrication and other components complied to Australian standards and specifications outlined by the client.

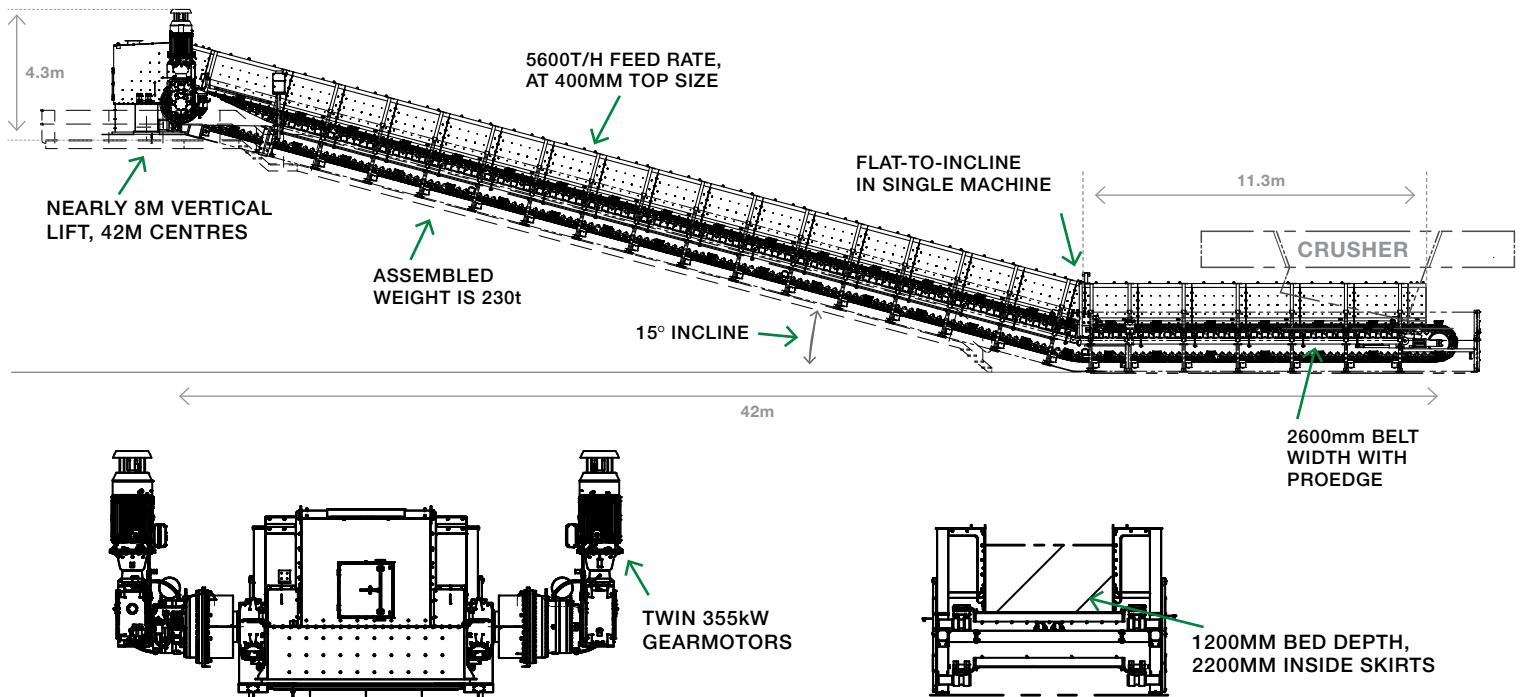

HEAD OFFICE

Western Australia

Local Call: 1300 127 091

International Call: +61 (0) 8 9270 8555

Email: wasales@transmin.com.au

Address: 33-37 Denninup Way Malaga
Perth, Western Australia, 6090

Queensland & Northern Territory

Local Call: 1300 800 609

International Call: +61 (0) 8 9270 8555

Email: qldsales@transmin.com.au

INTERNATIONAL OFFICES

North America Email: sales.ca@transmin.com.au

South America Email: sales.sa@transmin.com.au

India Email: sales.in@transmin.in

www.transmin.com.au