

CONVEYORPRO HEAVY DUTY COMPOSITE ROLLERS

ConveyorPro's new range of heavy duty composite rollers are designed for high speed and large tonnage applications.

BENEFITS

- ▶ Light weight up to 40% less than standard steel roller hence easier installation and handling;
- ▶ Friction welding will eliminate the separation risk of bearing house, permanently welded to the roller shell;
- ▶ Heavy duty application, high strength, high wear resistance, low friction co-efficient;
- ▶ Lubricated for life and multiple labyrinth seals;
- ▶ Corrosion free and chemical resistance;
- ▶ Low TIR make less vibration damage of bearing during high-speed operation;
- ▶ Suitable temperature range: -40°C to 80°C;
- ▶ Eliminates fatigue and stress points;
- ▶ Belt friendly - No pizza effects and sticky material to shed from roll;
- ▶ Less energy consumption; and
- ▶ Less noise compared to standard steel roller.

Shell Diameter (mm)	Bearing (SKF/FAG/NTN)	Belt Width (mm)
88.9	6204 6205	BW 450~2600
114.3	6204 6205	
127	6205 6305 6306	
133	6205 6305 6306	
152.4	6305 6306 6307 6308	
159	6305 6306 6307 6308	
165.2	6305 6306 6307 6308	
177.8	6306 6307 6308 6309 6310	
194	6306 6307 6308 6309 6310	
203	6307 6308 6309 6310 6312	
219	6307 6308 6309 6310 6312	

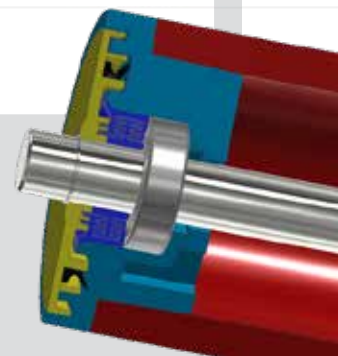

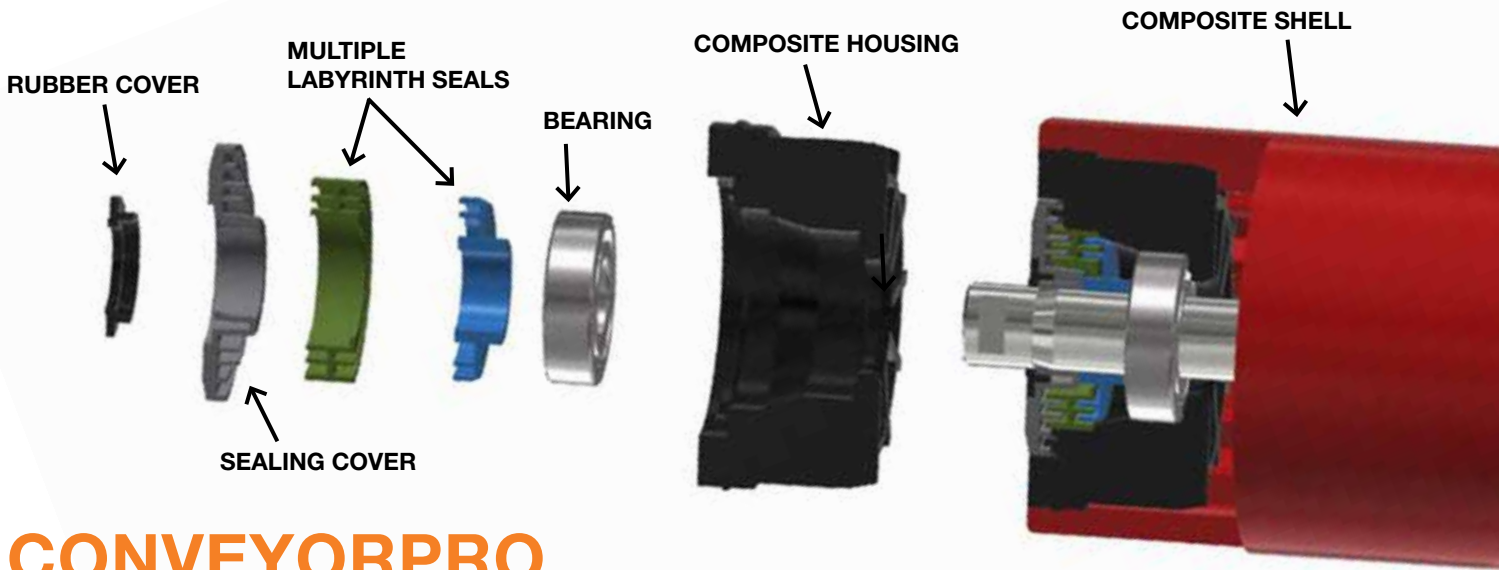

CONVEYORPRO MEDIUM DUTY COMPOSITE ROLLERS

ConveyorPro's new range of medium duty composite rollers are light weight and durable making them reliable for conveyor applications.

BENEFITS

- ▶ High wear resistance, low friction;
- ▶ Self-lubrication not easy to jam under bad conditions;
- ▶ Low TIR make less vibration damage of bearing during high-speed operation;
- ▶ Ambient temperature range: -40°C to 80°C;
- ▶ Light weight up to 40% less than standard steel roller hence easier installation and handling;
- ▶ Minimal shell deflection;
- ▶ Less noise compared to standard steel roller;
- ▶ Excellent corrosion and chemical resistance; and
- ▶ Less energy consumption.

Shell Diameter (mm)	Bearing (SKF/FAG/NTN)	Belt Range (mm)
88.9	6204 6205	BW 450-2400
101.6	6204 6205	
114.3	6204 6205	
127	6204 6205 6305 6306	
133	6204 6205	
139.8	6205	
152.4	6204 6205 6305 6306 6307 6308	
159	6205 6305 6306 6307 6308	

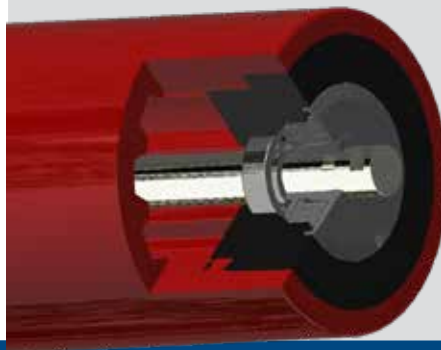

HEAD OFFICE

Western Australia

Local Call: 1300 127 091

International Call: +61 (0) 8 9270 8555

Email: wasales@transmin.com.au

Address: 33-37 Denninup Way Malaga
Perth, Western Australia, 6090

Queensland & Northern Territory

Local Call: 1300 800 609

International Call: +61 (0) 8 9270 8555

Email: qldsales@transmin.com.au

INTERNATIONAL OFFICES

South America Email: sales.sa@transmin.com.au

North America Email: sales.ca@transmin.com.au

India Email: sales.in@transmin.in

www.transmin.com.au