

Name: Company: Site: Email:

Phone: Equip ID:

ConveyorPro STEEL CORD CONVEYOR BELT

Please complete this enquiry form so that your requirements can be fully evaluated.

Refer to Diagram Page 3

| | | | | |
|-------------------------------|--------------------------|-----|-------------------|--|
| Material Handled | Designation | | | |
| | Temperature interval | | °C | |
| | Humidity | | % | |
| | Max. lump size | | mm | |
| | Lump size distribution | | % | |
| | Bulk density | | kg/m ³ | |
| | Chemically corrosive? | Yes | No | |
| | Oil? | Yes | No | |
| Mass Flow | Capacity | | t/h | |
| | Hrs per day operation | | hrs | |
| | days per year operation | | days | |
| | Belt speed | | m/s | |
| Pulley Center Distance | L0 | | m | |
| | L1 | | m | |
| | L2 | | m | |
| | L3 | | m | |
| | L4 | | m | |
| | L5 | | m | |
| Lift Height | Uphill | | Downhill | |
| | Lift of section lengths: | | | |
| | H1 | | m | |
| | H2 | | m | |
| | H3 | | m | |

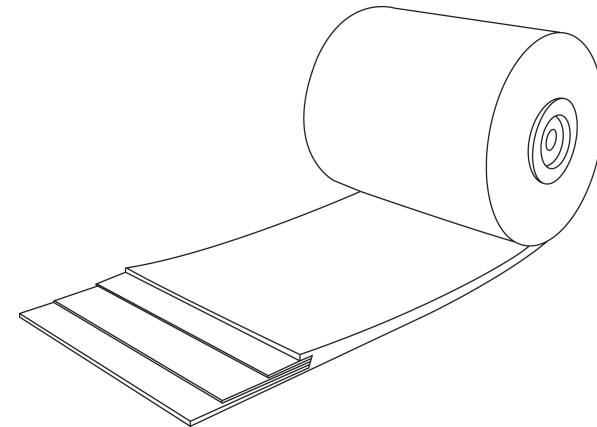

Proposed Site Visit

Special Comments

| | | | |
|---|---|-----------------|------|
| Lift Height | H4 | | m |
| | H5 | | m |
| | H6 | | m |
| Minimum Curve Radius | Horizontal | | m |
| | Vertical, convex | | m |
| | Vertical, concave | | m |
| Maximum Inclination in the Routing | | | ° |
| Belt Width | | | mm |
| Troughing angle in top strand, λ | | | ° |
| Idlers | Idler spacing in top strand | | m |
| | Idler spacing in top strand | | m |
| | Idler station type in top / bottom strand (1-, 2-, 3-, or 5-part) | Top: Bottom: | |
| | Idler diameter top strand | | mm |
| | Idler diameter bottom strand | | mm |
| Belt length | | | m |
| Take Up Configuration | (automatic / rigid / gravity at head / tail) | | |
| Belt Designation | Belt mass | | kg/m |
| | Belt type (EP / St etc) | | |
| | Number of plies (EP belt) | | |
| | Belt top cover thickness | | mm |
| | Belt bottom cover thickness | | mm |
| | Belt total thickness | | mm |
| | Rubber grade (M, W, DIN-K etc) | | |
| | Compliance standard (ISO, DIN etc) | | |
| | Splice type | | |

| | | | |
|--|---|----------------------------------|----|
| Motor Power Installed | Drive configuration (with or without frequency converter or hydraulic clutch) | | |
| | (Number of drives at head / intermediate / tail) | | |
| | Specific output kW | Drive 1: Drive 2: Drive 3: | |
| | Starting / braking time | | |
| | Drive pulley - diameter | | mm |
| | Wrap angle head drive pulley | | ° |
| | Lagging type head drive pulley | | |
| | Tail pulley - diameter | | mm |
| | Wrap angle tail drive pulley | | ° |
| | Lagging type tail pulley | | |
| | Snub pulley - diameter | | mm |
| | Wrap angle snub pulley | | ° |
| | Lagging type snub pulley | | |
| | Take-up pulley - diameter | | mm |
| | Wrap angle take-up pulley | | ° |
| Lagging type take-up pulley | | | |
| Rotating masses (if known) | | t | |
| Local Transport Limits for Belt Reels | Lmax x Hmax x Bmax | | M |
| | Max. reel weight | | T |
| Ambient Temperature Interval | | | °C |
| Chute Type (Feeding Conditions) | (impact wall, rock box, grizzly fingers, hood-spoon etc) | | |
| | Drop Height | | m |
| | Transfer / repose angle | | ° |
| | Skirting length (assuming both sides) | | m |
| | Covered, underground or tripper | | |

